

2017

EngineQuest®

SINCE 1987

CELEBRATING 30 YEARS OF SOLVING
ENGINE BUILDER PROBLEMS



EVERYTHING YOU NEED,
EVERY TIME!
ENGINEQUEST.COM



EVERYTHING YOU'RE LOOKING FOR IS RIGHT HERE!

Product	Page	Product	Page
ADAPTOR, DIPSTICK	12	MAIN BOLT, STUDED	20
ADAPTOR, REAR MAIN SEAL	12	MANIFOLD, EXHAUST	13
ALIGNMENT TOOL	12	MANIFOLD, INTAKE	13
BALANCE SHAFT ELIMIN. KIT	6	MARINE COMPONENTS	19-22
BLOCK CONVERSION JIG	6	MARINE INTAKE MANIFOLD	13
BLOCK TO TRANS. DOWEL	3	METRIC PIPE PLUG	11
CAM ECCENTRIC	4	OEM INTERCHANGE	28-29
CAM GEAR BOLT	5	OIL BAFFLE	20
CAM GEAR WASHER	5	OIL CAP	8
CAM PLUG	5	OIL FILTER ADAPTOR	10,19
CAM THRUST PLATE	4	OIL FILTER CONNECTOR	10,19
CAP	19	OIL GALLERY PLUG	3
CARBURETOR ADAPTOR	10	OIL PAN	8, 20
CONVERSION JIG	6	OIL PAN BOLT	20
COOLANT SYSTEM PLUG	3	OIL PAN RAIL	9, 20
CRANKSHAFT	7	OILER	12
CYLINDER HEAD	20, 23-26	PAN BOLT	20
CYLINDER HEAD ADAPTOR	10	PCV GROMMET	8
CYLINDER HEAD ASS.	21, 23-26	PERFORMANCE CYL. HEAD	27
CYLINDER HEAD BOLT	18, 20	PIN BUSHING	5
CYLINDER HEAD DOWEL	3	PIPE PLUG, JAPANESE	11
CYLINDER HEAD FLOW NUMBER	30	PIPE PLUG, METRIC	11
CYLINDER HEAD GASKET SET	26	PIPE PLUG, SAE	11
CYLINDER HEAD PLUG	11	PISTON PIN BUSHING	5
CYL. HEAD STUD, ROCKER ARM	26	PLUG, CYLINDER HEAD	11
CYLINDER HEAD, BARE	21, 23-26	PLUG, PIPE	11
DAMPENER	7, 19	PLUG, SMOG	11
DIPSTICK ADAPTOR	12	PUSH ROD COVER	16, 22
DOWEL PIN	3	REAR MAIN SEAL ADAPTOR	12
ELIMINATION KIT	6	ROCKER ARM GUIDE	
ENGINE OILER	12	PLATE CONVERSION	3, 4
ENGINE PRELUBER	12	ROCKER ARM SHAFT	4
EXHAUST MANIFOLD	13	ROCKER ARM STUD	26
FLOW NUMBERS	30	ROCKER COVER	19
FORKLIFT CYLINDER HEAD	26	ROLLER LIFTER GUIDE	3
FUEL PUMP BLOCK OFF GASKET	21	ROLLER LIFTER GUIDE	21, 22
FUEL PUMP BLOCK OFF PLATE	5, 21	ROLLER LIFTER RETAINER	3, 21-22
FUEL PUMP BLOCK OFF		ROLLER LIFTER SPYDER	3
PLATE GASKET	6	SAE PIPE PLUG	11
GASKET SET, CYLINDER HEAD	26	SIDE PLATE	16, 22
GROMMET	19	SMOG PLUG	11
HARMONIC BALANCER	7, 19	THERMALACTOR	11
HEAD BOLT	17, 18, 20	THRUST BUTTON	5
HEAD GASKET SET	26	TIMING CHAIN DAMPENER	5
INDUSTRIAL CYLINDER HEAD	26	TIMING CHAIN GUIDE	5
INTAKE MANIFOLD	13, 22	TIMING CHAIN TENSIONER	5
INTAKE MANIFOLD PLUG KIT	13	TIMING COVER	8, 14-16, 19
INTERCHANGE	28, 29	VALVE COVER	8, 19
JAPANESE PIPE PLUG	11	VALVE LASH CAP	3
JET VALVE ELIMINATION KIT	6	VALVE SPRING RETAINER	5
LASH CAP	3	WARRANTY	12
LS COOLANT PLUG	3	WINDAGE TRAY, BOLT	20

Customer Service

7am - 5pm Pacific Time

800/426-8771 • Local 702/649-7776 • Fax: 702/649-6777

Learn more at: Enginequest.com

ROCKER ARM GUIDE PLATE CONVERSION KIT

3/8" Rocker Arm Guide Plate Conversion Kit for Dodge/Ford:

It features premium heat treated studs and exclusive guide plates along with an adjustable configuration without machining. This conversion kit provides an easy way to convert net lash cylinder heads to:

- Guide plate Pushrod Size 5/16"
- Guide plates Included Yes
- Quantity Sold as a pair
- Rocker Arm Nuts included No
- Rocker Arm Studs included Yes
- Rocker Arms included No
- Rocker Stud Thread Diameter 3/8" - 24"

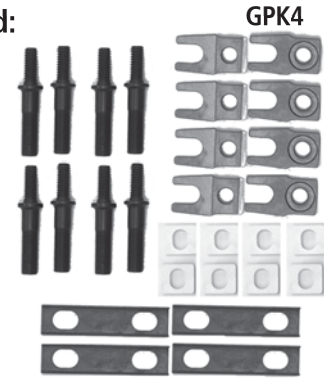

ROLLER LIFTER RETAINERS

DESCRIPTION	YEARS	PART #	ITEM
SMALL BLOCK CHEV V8	1986 - 97	RLG350	CLIP / GUIDE
SMALL BLOCK CHEV V8	1986 - 97	RLR350N	RETAINER
SMALL BLOCK CHEV V8	1986 - 97	RLR350KIT	RETAINER, 3 MOUNTING BOLTS, 8 CLIPS
SMALL BLOCK CHEV V8	1987 - 90	RLRDLXA	RETAINER, 3 MOUNTING BOLTS, 8 CLIPS, CAM THRUST PLATE (4.23" T2T), CAM THRUST PLATE MOUNTING BOLTS
SMALL BLOCK CHEV V8	1991 - 02	RLRDLXB	RETAINER, 3 MOUNTING BOLTS, 8 CLIPS, CAM THRUST PLATE (3.900" T2T), CAM THRUST PLATE MOUNTING BOLTS
BIG BLOCK CHEV V8		RLG454	CLIP / GUIDE

DOWEL PINS, MISC. PARTS

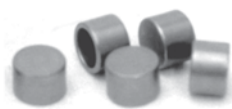

LC302



DP302/DP390/TC302

EQ#	Description
HD173	CHEVROLET V6 173 CID HEAD TO BLOCK DOWEL
HD350	CHEVROLET SMALL BLOCK CYL. HEAD TO BLOCK DOWEL
HD454	CHEVROLET BIG BLOCK CYLINDER HEAD DOWEL
BDV8F	FORD V8 BLOCK TO TRANS DOWEL HEAD 6397AB
LC302	FORD 302/351W V8 VALVE CAP
DP302	FORD SMALL BLOCK V8 HEAD TO BLOCK DOWEL OEM #C20Z6A008A



CHEVROLET LS OIL GALLEY PLUG

EQ#	Description
OGP294N	CHEVROLET LS OIL GALLEY PLUG OIL GALLEY PLUG LS1 LS3 LS4 LS7 L99 LSA REPLACES OEM # 12573460
BP085N	CHEVROLET LS COOLANT SYSTEM AIR BLEED PLUG 1997-2003 GM LS Series REPLACES GM # 12602540

All cooling systems need high-quality components to function well and provide maximum cooling ability. EngineQuest coolant system air bleed plugs are made of steel and are designed to bleed air from cooling systems to avoid any major issues. It's highly recommended that two air bleed plugs be used per engine to complete the bleeding process for the very best results.

CHEVROLET LS COOLANT SYSTEM AIR BLEED PLUG

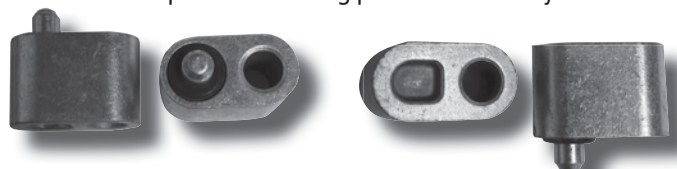

NEW CAM ECCENTRICS

PART #	DESCRIPTION
CE120I	FORD V8 255, 302, 351W, 400, 460 INNER CAM ECCENTRIC (UP TO 85)
CE1200	FORD V8 255, 302, 351W, 400, 460 OUTER CAM ECCENTRIC (UP TO 85)
CE121N	FORD V8 255, 302, 351W, 400 CAM ECCENTRIC (85 & UP) WASHER
CE124N	AMC V8 (INCL. DIST. GEAR, SPACER, WASHER & BOLT)
CE129N	TOYOTA 22REC (INCLUDES DRIVE GEAR, BOLT & WASHER)
CE390N	FORD 360/390 2 PIECE CAM ECCENTRIC



CAM THRUST PLATES

PART #	APPLICATION	OEM #
CP250N	CHEVROLET 230, 250, 292 (63-93), PONTIAC 151 (R CODE)	10000568
CP301N	PONTIAC 301, 400, 455	
CP302N	FORD 289, 302, 351W (67-86)	C90Z6269A
CP349N	CHEVROLET 305, 350 3.90" TIP TO TIP	
CP350N	CHEVROLET 305, 350 4.23" TIP TO TIP ROLLER CAM	10168501
CP349N	454 BIG BLOCK WITH ROLLER CAM	
CP460N	FORD 351M, 400, 429, 460 (68-91)	C8SZ6269A

NOTE: SOLD IN 5 PACKS ONLY

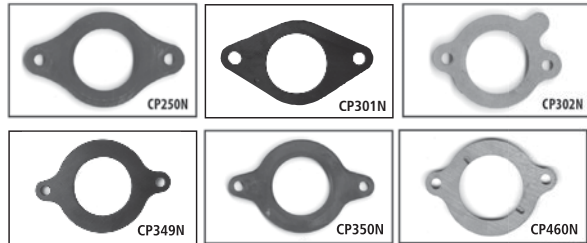

ROCKER ARM GUIDE

PART #	APPLICATION
RGFO	<ul style="list-style-type: none"> <li style="width: 33%;">• 2.5 HSC <li style="width: 33%;">• 351C <li style="width: 33%;">• 400 <li style="width: 33%;">• 300 L <li style="width: 33%;">• 351M <li style="width: 33%;">• 460 <li style="width: 33%;">• 302 <li style="width: 33%;">• 351W
STEEL GUIDE THAT GOES BELOW THE ROCKER ARM FULCRUM. REPLACES FORD # ESTZ6A588A	



ROCKER SHAFT ASSEMBLY

PART #	MFG	VEHICLE	ENGINE	NOTES
RA360N	FORD	CAR & TRUCK	352,360,390, 410,427,428	ALL NEW. NON-ADJUSTABLE

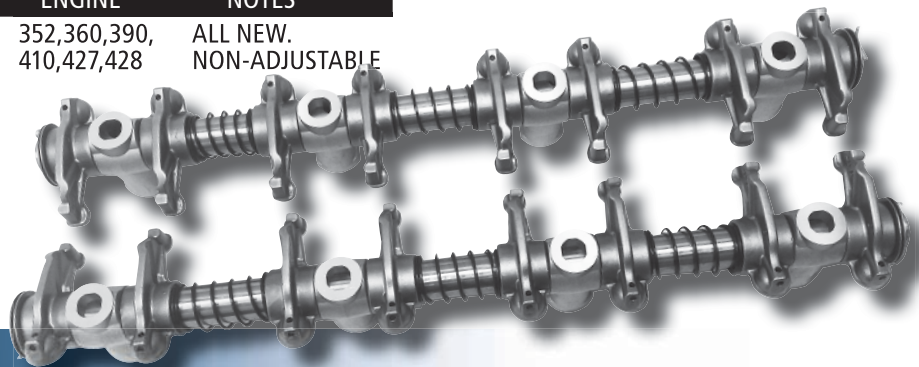

CAMSHAFT PRODUCTS

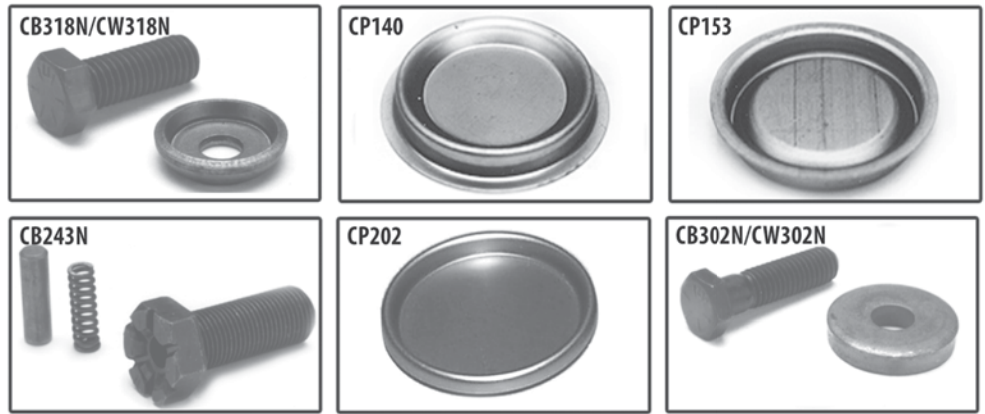

PART #	MFG	APPLICATION	DESCRIPTION	OEM #
CB243N	AMC/JEEP	LATE MODEL 4.0 & 4.2L	NEW CAM GEAR BOLT	83502890
CP202	CHRYSLER	3.3 & 3.8L	NEW CAM PLUG	4483620
CB318N	CHRYSLER	V8 318 & 360 CID UP TO 1991	NEW CAM GEAR BOLT	
CW318N	CHRYSLER	V8 318 & 360 CID UP TO 1991	NEW CAM GEAR WASHER	1618732
CB302N	FORD	V8 255, 302, 351W, 400	NEW CAM GEAR BOLT	
CB390N	FORD	FE 360 390 V8	CAM GEAR BOLT	
CW302N	FORD	V8 255, 302, 351W, 400	NEW CAM GEAR WASHER	C1TE6278A
CP140	FORD	140 CID HSC (1987)	CAM PLUG - 2.210" OD	E43E6266A
CP153	FORD	2.3 & 2.5L HSC (88 - UP) 3.0L V6	CAM PLUG - 2.230" OD	E6AE6266BA

TIMING TENSIONERS/COMPONENTS



PART #	MFG.	ENGINE	DESCRIPTION	OEM #	YEARS
TB181	BUICK	V6 3.8L 231 CID	CAMSHAFT ROLLER TYPE THRUST BUTTON	25532588	85-88
TD174	CHEV	V6 2.8L, 3.1L 173, 189 CID	TIMING CHAIN DAMPENER	14078822	89-95
TT140	FORD	2.3L 140 CID OHC	TIMING BELT TENSIONER SPRING	D4FZ6L273A, F47Z6L273A	74-99
TB140N	FORD	2.3L 140 CID OHC	TENSIONER SPRING STUD	E9TZ6K282A	74-99
TB141N	FORD	2.3L 140 CID OHC	TENSIONER SPRING STOP	E7Z26E008A	74-99
TT055	FORD	2.9L 177 CID	TIMING CHAIN GUIDE	E6T26K297A	86-90
TT232A	FORD	3.8L 232 CID, 4.2L 256 CID	TIMING CHAIN TENSIONER	1F2Z6K254AA	89-99

PISTON PIN BUSHINGS

Compare Our Quality... on our large selection of boreable and honeable bushings.



MFG	ENGINE	YEAR	HONEABLE	OD	ID	LENGTH	QTY	BOREABLE	OD	ID	LENGTH	QTY
CHRY	2.7L	98-03						PB167B	.9432	.9451	.8750	6
CHRY		57-73	PB318H	1.039	.976	1.185	8	PB318B	1.039	.964	1.185	8
TOYOTA	20R, 22RE, 85-95 22REC		PB22RH	.949	.870	1.087	4	PB22R	.949	.837	1.087	4

VALVE SPRING RETAINERS

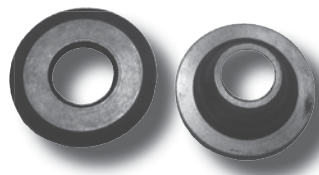

PART #	APPLICATION
VSR318N	AMC 150 2.5L, 242 4.0L , DODGE 318 5.2L, 360 5.9L
VSR244N	FORD 177 2.9L, 244 4.0L

BULK PACK AVAILABLE

FUEL PUMP BLOCK OFF PLATES

BOP076 - Universal Style Plate with Gasket

GOP076 - Universal Style Gasket

- Fits:*
- Fords - all except 2.8L, 351C, 351M, 400
 - Dodge - all domestic
 - Pontiac - all V8
 - Chevrolet - Big Block, 250, 292
 - AMC - 6 CYL, V8
 - Buick - V6, V8



BOP087 - Small Block Chevrolet with Gasket

GOP087 - Small Block Chevrolet Gasket

Gasket Fits Chevrolet - all small block (4 hole)

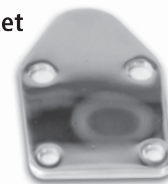

BLOCK & HEAD CONVERSION JIGS

NOTE: ALL TOOLING NON-RETURNABLE



CJ262

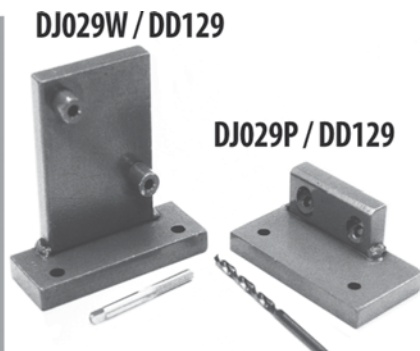

DJ029P / DD129



CJ305

PART #	DESCRIPTION
CJ262	CONVERT CHEVROLET 4.3L 262 CID BLOCKS W/ELECTRIC FUEL PUMPS TO ACCEPT MECHANICAL FUEL PUMP (INCL. DRILL BITS AND REAMERS)
CJ305	CONVERT CHEVROLET SMALL BLOCKS W/ELECTRIC FUEL PUMPS TO ACCEPT MECHANICAL FUEL PUMP (INCL. DRILL BITS AND REAMERS).
DJ029P	MOUNTING AND DRILLING JIG FOR CHEVROLET PAN RAIL STYLE DIPSTICK ADAPTOR (100% ACCURATE EACH AND EVERY TIME).
DT129	TAP USED WITH DA026P AND DA026W.

ELIMINATION KITS

PART #	DESCRIPTION
BEK122	BALANCE SHAFT Chrysler/Mitsubishi 1.8L, 2.0L, 2.4L, G62B, G63B, 4G63B, G64B, 4G64B (belt drive applications) KIT INCLUDES: Upper & lower bushings, balance shaft replacement pin, oil galley block-off plug.
BEK156	BALANCE SHAFT Chrysler/Mitsubishi 2.6L KIT INCLUDES: Replacement bushing, balance shaft replacement pin, oil pump drive chain.
BEK157	BALANCE SHAFT Chrysler/Mitsubishi 2.6L KIT INCLUDES: Replacement bushing, balance shaft replacement pin, oil pump drive chain, chain guide, crank guide, crank gear, oil pump gear.
JVE156	JET VALVE Chrysler/Mitsubishi 2.6L Replaces jet valves in cylinder heads for use in non jet valve applications. Fits many other applications where OEM Jet Valve #MD009440 is used.

BEK122



BEK156



BEK157



JVE156



K21 Nissan Forklift Crankshaft

Replaces Part Number: 91H20-00990 N-12201-FU400
 Part# CSK21N Includes: 1pc Only – no bearings
 Standard Size Rod and Main journals
 Rod Journal Diameter 1.7701-1.7706" (44.961-44.974 MM)
 Main Journal Diameter 2.4780-2.4785" (62.942-62.955 MM)

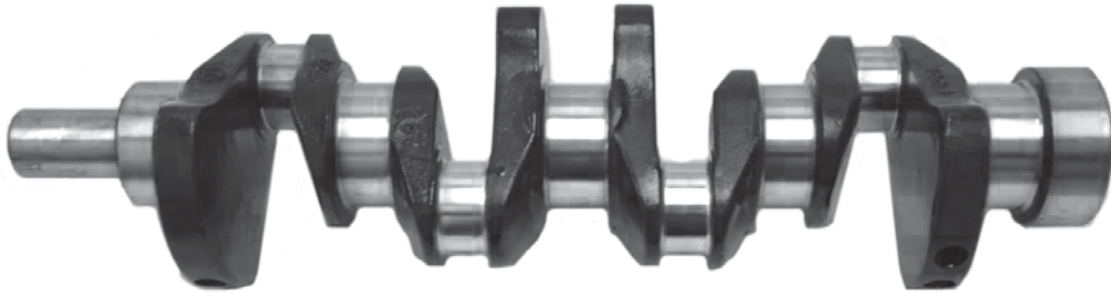

HARMONIC BALANCERS

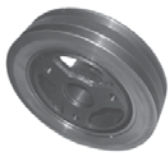

BA251N



BA289N



BA304N



BA305N



BA349N



BA350N



BA390N



BA396N



BA400N



BA460A

PART #	MFG	LITERS	CID	YEARS	NOTES
BA251N	Chev	4.1	250	75-76	Double Groove, 1/2" Spacing
BA349N	Chev	5.0, 5.7	305, 350	69-93	Car & Truck 8" Solid
BA350N	Chev	5.0, 5.7	305,350	69-95	Car & Truck 6-3/4" Solid
BA304N	Chev	5.0, 5.7	305, 350	77-86	Car & Truck 8" Hollow
BA305N	Chev	5.0, 5.7	305, 350	79-93	Car & Truck 6-3/4" Hollow
BA396N	Chev	6.5	396	65-72	Big Block
BA400N	Chev	6.6	400	69-80	Small Block
BA289N	Ford	4.7	289	65-69	3 bolt
BA390N	Ford	5.9, 6.4, 7.0	360, 390, 427, 428	66-76	Car & Truck
BA460A	Ford	7.0, 7.5	429, 460	68-97	Truck D9TE

Visit www.enginequest.com for complete warranty, terms of use and terms of sale.

NEW OEM TYPE TINWARE

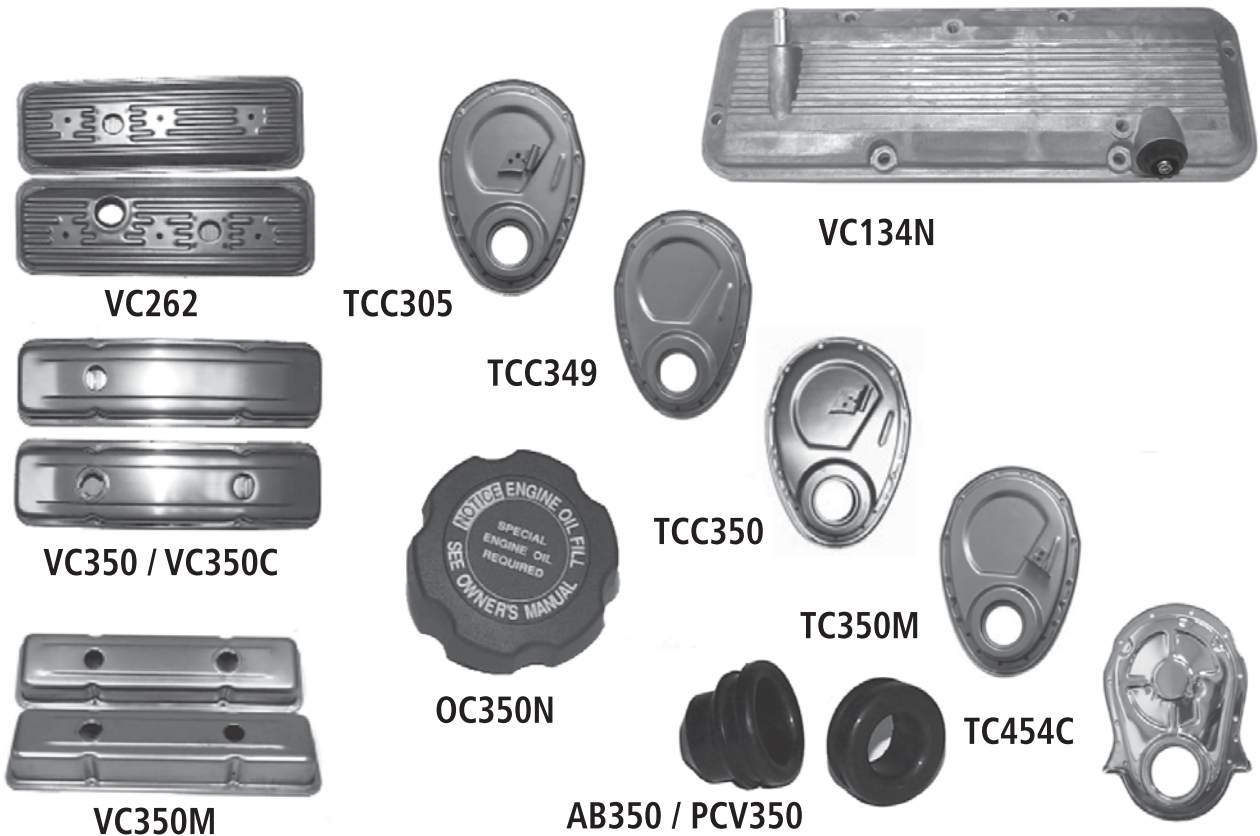

Part #	DESCRIPTION	APPLICATIONS	YEARS
VC134N	VALVE COVER	GM 2.2L	1995 – 1997
VC262	VALVE COVER SET	CHEVROLET 4.3L 262	1986 & UP - METAL
VC350	VALVE COVER SET	CHEVROLET SMALL BLOCK	UP TO 1985
VC350M	VALVE COVER SET	CHEVROLET SMALL BLOCK	UP TO 1985
VC350L	VALVE COVER SET	CHEVROLET SMALL BLOCK	1 BREATHER & 1 FILLER PER SIDE 1986 & UP, 1 PUSH IN / 2 PUSH IN
VC351L	VALVE COVER SET	CHEVROLET SMALL BLOCK	1986 & UP, 1 PUSH IN & 1 SCREW IN / 1 PUSH IN
VC352L	VALVE COVER SET	CHEVROLET SMALL BLOCK	1986 & UP, 1 PUSH IN & 1 SCREW IN PER SIDE
VC300N	VALVE COVER	FORD 4.9L 300 CID	TALL FILLER NECK
TCC305	TIMING COV. BL.K PAINTED	CHEVROLET SMALL BLOCK	W/ 6-3/4" BALANCER 80-UP W/WELDED TAB
TCC349	TIMING COV. BL.K PAINTED	CHEVROLET SMALL BLOCK	NO TIMING MARKER UP TO 85
TCC350	TIMING COV. BL.K PAINTED	CHEVROLET SMALL BLOCK	WITH 8" BALANCER UP TO 79
TC350C	TIMING COVER CHROMED	CHEVROLET SMALL BLOCK	FOR BOLT-ON MARKER
TM350C	TIMING COVER MARKER CHROMED	CHEVROLET SMALL BLOCK	BOLT ON TIMING MARKER
TC350M	TIMING COV. BL.K PAINTED	CHEVROLET SMALL BLOCK	MARINE MARINE 86 & UP
TC262P	TIMING COVER PLASTIC	CHEVROLET 4.3L	1996 – 2000 INCLUDES SENSOR HOLE PLUG
TC350P	TIMING COVER PLASTIC	CHEVROLET SMALL BLOCK	1996 – 2000 INCLUDES SENSOR HOLE PLUG
TCC454	TIMING COV. BL.K PAINTED	CHEVROLET BIG BLOCK	1968 - 1990
TM454C	TIMING COVER MARKER CHROMED	CHEVROLET BIG BLOCK	1968 - 1990
DT454C	DIPSTICK & TUBE CHROMED	CHEVROLET BIG BLOCK	1968 - 1990
PCV350	PCV GROMMET RUBBER	PCV GROMMET RUBBER	1986 & UP
OC350N	SCREW IN OIL CAP	UNIVERSAL	1986 & UP

PART	MFG	APPLICATION	ENG	LITERS	YEARS	NOTES
OP134N	CHEV	S10 / SONOMA	134	2.2	1997-03	WITHOUT SENSOR
OP262M	CHEV	MARINE	262	4.3	1986-93	1 PIECE REAR SEAL APPLICATION
OP350C	CHEV	CAR, PICKUP & VAN	305	5.0	1970-79	CHROME / LEFT DIP
OP350E	CHEV	CAR, PICKUP & VAN	305	5.0	1970-79	LEFT DIP
OP350B	CHEV	CAR, PICKUP & VAN	305	5.0	1970-79	LEFT DIP 6 QUART WITHOUT BAFFLE
OP350BC	CHEV	CAR, PICKUP & VAN	305	5.0	1970-79	CHROME LEFT DIP 6 QUART W/OUT BAFFLE
OP305C	CHEV	CAR, PICKUP & VAN	305	5.0	1980-85	CHROME / RIGHT DIP
OP305L	CHEV	CAR, PICKUP & VAN	305	5.0	1980-85	RIGHT DIP
OP304C	CHEV	CAR, PICKUP & VAN	305	5.0	1986-00	CHROME
OP350L	CHEV	CAR, PICKUP & VAN	305	5.0	1986-00	4 QUART PAN
OP350M	CHEV	MARINE	305	5.0	1986-96	5 QUART W/OUT BAFFLE 1/2" DRAIN PLUG
OP350C	CHEV	CAR, PICKUP & VAN	350	5.7	1970-79	CHROME / LEFT DIP
OP350E	CHEV	CAR, PICKUP & VAN	350	5.7	1970-79	LEFT DIP
OP350B	CHEV	CAR, PICKUP & VAN	350	5.7	1970-79	LEFT DIP 6 QUART WITHOUT BAFFLE
OP350BC	CHEV	CAR, PICKUP & VAN	350	5.7	1970-79	CHROME LEFT DIP 6 QUART W/OUT BAFFLE
OP305C	CHEV	CAR, PICKUP & VAN	350	5.7	1980-85	CHROME / RIGHT DIP
OP305L	CHEV	CAR, PICKUP & VAN	350	5.7	1980-85	RIGHT DIP
OP304C	CHEV	CAR, PICKUP & VAN	350	5.7	1986-00	CHROME
OP350L	CHEV	CAR, PICKUP & VAN	350	5.7	1986-00	4 QUART PAN
OP350M	CHEV	MARINE	350	5.7	1986-96	5 QUART W/OUT BAFFLE 1/2" DRAIN PLUG
OP350N	CHEV	MARINE	350	5.7	1989-96	12MM DRAIN PLUG WITHOUT BAFFLE
OP350P	CHEV	MARINE, ESCLADE, C1500, C2500, C3500, K1500, K2500, K3500, TAHOE, YUKON	350	5.7	1989-02	5 QUART 14MM DRAIN PLUG WITH BAFFLE
OP454	CHEV	CAR & TRUCK	396	6.5	1965-90	2 PIECE REAR SEAL APPLICATION
OP350C	CHEV	CAR, PICKUP & VAN	400	6.6	1970-79	CHROME / LEFT DIP
OP350E	CHEV	CAR, PICKUP & VAN	400	6.6	1970-79	LEFT DIP
OP350B	CHEV	CAR, PICKUP & VAN	400	6.6	1970-79	LEFT DIP 6 QUART WITHOUT BAFFLE
OP350BC	CHEV	CAR, PICKUP & VAN	400	6.6	1970-79	CHROME / LEFT DIP 6 QUART W/OUT BAFFLE
OP454	CHEV	CAR, PICKUP & VAN	454	7.4	1965-90	2 PIECE REAR SEAL APPLICATION
OP302A	FORD	BRONCO, P/UP / VAN	302	5.0	1980-96	

OIL PAN RAIL SET

PART #	ENGINE MFG	CID	LITER	YEARS	NOTES
OPR262	Chevrolet	262	4.3	1986-93	For use on 1 piece rear seal engine and with oil pan part # OP262M
OPR350	Chevrolet	305	5.0	1985-02	For use on 1 piece rear seal engine
OPR350	Chevrolet	350	5.7	1985-02	For use on 1 piece rear seal engine



OPR262

OIL FILTER ADAPTORS



OFA294A



OFA294B

PART #	MFG	APPLICATION	YEAR	OEM#	QTY
OFA258	AMC/JEEP	4.0L 244 CID	81-86	J3173226	5
OFA258	AMC/JEEP	4.2L 258 CID	81-86	J3173226	5
OFA304	AMC/JEEP	5.0L 304 CID	70-81		5
OFA304	AMC/JEEP	5.9L 360 CID	70 -91		5
OFA304	AMC/JEEP	6.6L 401 CID	70 -78		5
OFA173	CHEV	1.8L	82-UP	466383	5
OFA173	CHEV	2.0L	82-UP	466383	5
OFA173	CHEV	2.8L 173 CID	82-UP	466383	5
OFA262	CHEV	4.3L 262 CID	86 -UP	14081300	10
OFA305	CHEV	SMALL BLOCK		3952301	EACH
OFA454	CHEV	BIG BLOCK		3853870	5 *
OFA294A	CHEV	4.8, 5.3, 6.0, 6.2L		12600225	5 *
OFA294B	CHEV	4.8, 5.3, 6.0, 6.2L		12552357	5 *
OFA345	CHRYSLER	5.7L HEMI		4104511A	10 *
OFA098	FORD	1.6L 98 CID	81-85	F4FZ6890A	5
OFA183	FORD	3.0L 183 CID	86-91	E6DZ6890A	5
OFA244	FORD	4.0L 244 CID	92-98	FOTZ6890A	5
OFA302	FORD	3.8L 232 CID	86-96	D7AZ6890A	10 *
OFA302	FORD	4.9L 300 CID	86-96	D7AZ6890A	10 *
OFA302	FORD	5.0L 302 CID	86-96	D7AZ6890A	10 *
OFA302	FORD	5.8L 351W CID	86-96	D7AZ6890A	10 *
OFA460	FORD	7.5L 460 CID		C9AE6890A	5
OFA142	OLDS	2.3L QUAD 4	87-UP	22538711	5

ASSORTMENT PACK

OFA17A - ASSORTMENT PACK CONTAINS:

- (1) OFA098
- (2) OFA151
- (2) OFA173
- (2) OFA183
- (2) OFA244
- (4) OFA262
- (4) OFA302

**ALL IN BOX, EASY TO USE
AND CLEARLY MARKED!**

*Bulk packaging available

CARBURETOR ADAPTOR

A MUST FOR FORD AUTO RESTORERS!

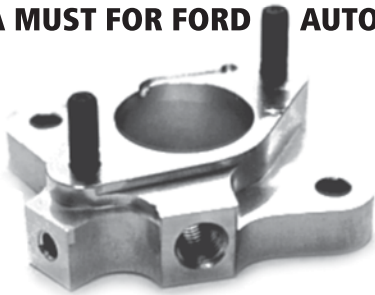

CA200 - Converts 1970-79 200/250 CID Ford Engines with 1-3/4" carburetor mount to fit in pre-1969 engines with 1-1/2" carburetor mount. Looks factory original.

ALL ITEMS MANUFACTURED WITH THE

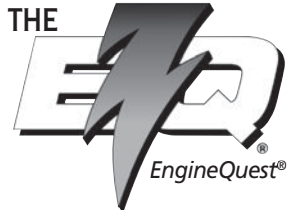

DIFFERENCE

CYLINDER HEAD ADAPTORS

ONE OF THE FIRST ITEMS WE DESIGNED TO HELP REBUILDERS SOLVE THEIR PROBLEMS!

Use early small block Chevrolet heads with 6 exhaust bolt holes in place of 7 bolt hole heads. No need to sell your customer a different head or manifold.



**AH034 -
Add a 7th Hole**

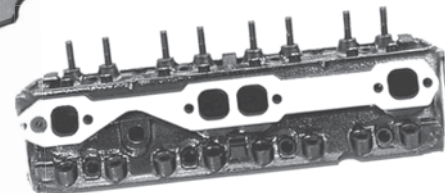

REPLACEMENT PIPE PLUGS

JPP05A - ASSORTMENT PACK

CONTAINS: 5 OF EACH SIZE



Part #	Size	Std Package
JPP001	1/8" - 28	25
JPP002	1/4" - 19	25
JPP002BLK	1/4" - 19	500
JPP003	3/8" - 19	25
JPP003BLK	3/8" - 19	500
JPP004	1/2" - 14	25
JPP005	3/4" - 14	25
JPP001	1/8" - 28	25

JAPANESE THREADS FOR TOYOTA & MITSUBISHI
PIPE PLUGS HAVE SEALANT ON THREADS

METRIC PIPE PLUGS

WITH VIBRA-SEAL COATING ON THREADS

MPP05A - ASSORTMENT PACK

CONTAINS: 5 OF EACH SIZE



PART#	THREAD SIZE	HEIGHT	SOCKET DRIVE	SOCKET DEPTH	QTY
MPP001	8MM -1.0	8MM	4MM	4MM	25
MPP002	10MM-1.0	8MM	5MM	4MM	25
MPP003	12MM-1.5	10MM	6MM	5MM	25
MPP004	14MM-1.5	10MM	7MM	5MM	25
MPP005	16MM-1.5	10MM	8MM	5MM	25
MPP006	18MM-1.5	10MM	8MM	5MM	25
MPP007	20MM-1.5	10MM	10MM	5MM	25
MPP008	22MM-1.5	10MM	10MM	5MM	25
MPP009	24MM-1.5	12MM	12MM	6MM	25

STANDARD PIPE/SMOG PLUGS

SPP25A - ASSORTMENT PACK

CONTAINS: 25 OF EACH SIZE



STANDARD PIPE PLUGS WITH VIBRA-SEAL COATING

Part #	Size	Std Package
SPP062	1/16" X .300"	50
SPM062	1/16" X .300"	1000
SPP125	1/8" X .300"	50
SPM125	1/8" X .300"	1000
SPP250	1/4" X .375"	50
SPM250	1/4" X .375"	1000
SPP251	1/4" X .460"	50
SPM251	1/4" X .460"	1000
SPP375	3/8" X .375	50
SPM375	3/8" X .375	1000
SPP500	1/2" X .550"	25
SPM500	1/2" X .550"	1000

ALL SPP#s AVAILABLE IN 1000 PACK

SMOG PLUGS



SP151/FTP034

SP300L

PART#	DESCRIPTION	QTY
SP151	CHEVROLET 250, 292 CID, PONTIAC 151CID SMOG PLUG -3/4" x 18"	10
SP300E	FORD 300 CID SMOG PLUG PRE '84-V8, 330, 360, 361HD, 390, 391HD-1/2" X20" x.55"	10
SP300L	FORD 300 CID SMOG PLUG '84 AND UP- 9/16" x 18" x.55	10
FTP034	FORD V8 255, 302, 351C, 351M, 351W, 400 THERMALACTOR PLUG 5/8" -11" ODX7/16" -14 ID	25

FTPBLK ALSO AVAILABLE-500 PACK

CONVERSION REAR MAIN SEAL HOLDERS

CHEVROLET 1986 - UP, V6 262 CID & V8 SMALL BLOCK

THE CHOICE IS YOURS - USE EARLY OR LATE STYLE OIL PAN

ENABLES A REBUILDER TO INSTALL A 2-PC. DESIGN CRANKSHAFT IN A 1-PC. SEAL DESIGN APPLICATION. MANUFACTURED FROM BILLET ALUMINUM.

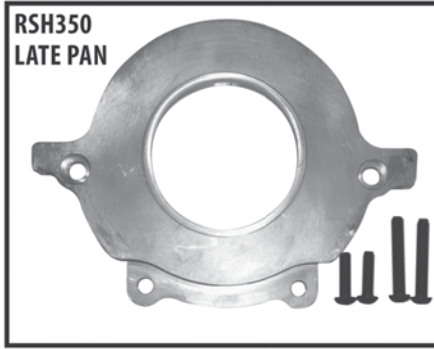
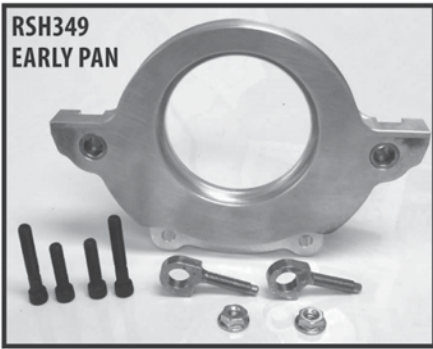

AT350 ALIGNMENT TOOL
FOR USE WITH RSH349 & RSH350
CONVERSION SEAL HOLDERS

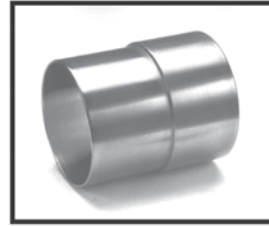

DIPSTICK TUBE ADAPTORS

CHEVROLET & FORD ADAPTORS MAKE YOUR EARLY BLOCKS LATE!

OPPOSITE SIDE DIPSTICK ADAPTORS CONVERT PRE-1980 CHEVY SMALL BLOCKS TO 1980 THRU 1985

PART#	DESCRIPTION
DA026P	BOLT-ON PAN RAIL (HAS ANGLED BOLT HOLES)
DA027	WELD-ON (WITH DIPSTICK TUBE HOLE DRILLED)



DA026P

ENGINE PRE-LUBER

PRESSURIZED PRE-LUBING AN ENGINE IS RECOMMENDED BY THE PRODUCTION ENGINE REMANUFACTURERS ASSOC. (PERA)

- INCLUDES MOUNTING ADAPTORS AND HOSE
- THE BEST FOR CRANK & CHAIN DRIVEN OIL PUMPS
- ELIMINATES DRY ENGINE STARTS
- MOUNTS TO OIL SENDING UNIT
- HOLDS UP TO 5 QUARTS OF OIL
- SIMPLE AND EASY TO USE, REUSABLE
- PRESSURIZES OILING SYSTEM
- (IMPORTANT ON WAREHOUSED MOTORS)



PL40

ENGINEQUEST WARRANTY

CURRENT WARRANTY TERMS AND CONDITIONS ARE AVAILABLE AT:

<http://www.aamidwest.com/enginequest/warranty/>

INTAKE MANIFOLD

PART #	ENG. MFG	CID	LITER	YEAR	CROSS REF.
IN350MB	Chevrolet	305	5.0	1997-95	
IN350MB	Chevrolet	350	5.7	1997-95	
IN350MA	Chevrolet	305	5.0	1996-02	17618T
IN350MA	Chevrolet	350	5.7	1996-02	17618T

NOTES:

- 4 Barrel Universal Carburetor mounting
- 15 degree carb flange
- All required mounting and accessories holes are tapped
- Superior runner finish for increased air flow
- CNC machined for exact fit and bolt hole location
- Manufactured of the highest grade of cast iron to resist salt water corrosion that aluminum intakes experience & corrosion caused by natural gas and other dry fuels.
- Electric Choke

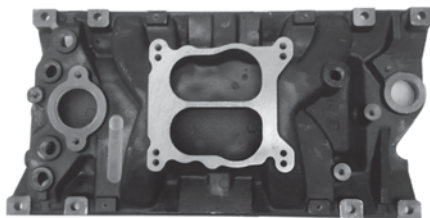

INTAKE MANIFOLD PLUG KIT

PART #	MFG	VEHICLE	ENGINE	LITERS	YEARS	NOTES
PKIN350	CHEV	CAR, TRUCK, MARINE & INDUSTRIAL	350	5.7	ALL	ALL THE PIPE PLUGS NEEDED TO BLOCK THE THREADED HOLES IN IN350MA & IN350MB



EXHAUST MANIFOLDS

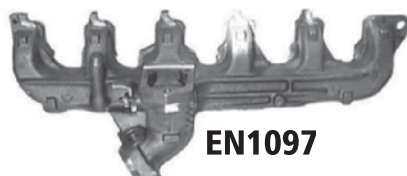

PART #	MFG	VEHICLE	ENGINE	LITER	YEAR	SIDE	NOTES
EN1097	FORD	TRUCK	300	4.9	81-86	-	WITH O2 SENSOR HOLE
IN887	FORD	TRUCK	300	4.9	77-86	INTAKE	-
EWM300	FORD	TRUCK	300	4.9	77-86	-	MOUNTING WASHERS
EN1698	FORD	TRUCK	460	7.5	88-97	RIGHT	-
EN1699	FORD	TRUCK	460	7.5	88-97	LEFT	-
EN1267C	CHEV	TRUCK		2.5	87-93	-	CAST IRON

ALL ITEMS MANUFACTURED WITH THE



DIFFERENCE

TIMING COVERS

PART #	MFG	VEHICLE	ENG.	LITERS	YEAR	CASTING / OEM#	NOTES	TYPE
TC231J	CHRYSLER	Wrangler	230	3.8	07-11	04666020AA, OEM # 68003438AC, 68003438AA, 68003438AB		N
TC361N	AMC	290	4.7		66-69	J8129373, 3226242		N
TC361N	AMC	304	5.0		70-81	J8129373, 3226242		N
TC361N	AMC	343	5.6		67-69	J8129373, 3226242		N
TC361N	AMC	360	5.9		70-91	J8129373, 3226242		N
TC361N	AMC	390	6.4		68-70	J8129373, 3226242		N
TC361N	AMC	401	6.6		70-78	J8129373, 3226242		N
TC14FR	BUICK	FWD CAR	181	3.0	82-85		14 BOLT OIL PAN	RM
TC181A	BUICK	181	3.0		85-85	25523276	SPLINED OIL PUMP DRIVE, 1 BYPASS NIPPLE	RM *
TC181B	BUICK	181	3.0		86-86	25524607	SPLINED OIL PUMP DRIVE, 2 BYPASS NIPPLE	RM *
TC181C	BUICK	181	3.0		86-88	25524607, 25530946, 25531877, 25526382	2 FLATS ON OIL PUMP DRIVE, 2 BYPASS NIPPLE, REAR FACING OIL FILTER ADAPTOR	RM *
TC181D	BUICK	181	3.0		86-88	25526382, 25531877, 25529279, 25530946	2 FLATS ON OIL PUMP DRIVE, 2 BYPASS NIPPLE, FRONT FACING OIL FILTER ADAPTOR, WITH CAM SENSOR HOLE	RM *
TC231RN	BUICK	RWD CAR	231	3.8	78-84		14 BOLT OIL PAN	N
TC14FR	BUICK	FWD CAR	231	3.8	84-85		14 BOLT OIL PAN	RM
TC20FR	BUICK	FWD CAR	231	3.8	85-85	25522652	20 BOLT OIL PAN	RM
TC231RN	BUICK	CAR RWD	231	3.8	85-89	25522651	20 BOLT OIL PAN	N
TC181C	BUICK	231	3.8		86-87	25524607, 25530946, 25531877, 25526382	2 FLATS ON OIL PUMP DRIVE, 2 BYPASS NIPPLE, REAR FACING OIL FILTER ADAPTOR	RM *
TC181D	BUICK	231	3.8		86-87	25526382, 25531877, 25529279, 25530946	2 FLATS ON OIL PUMP DRIVE, 2 BYPASS NIPPLE, FRONT FACING OIL FILTER ADAPTOR, WITH CAM SENSOR HOLE	RM *
TC181E	BUICK	CAR	231	3.8	89-90	25532382, 25533496	2 FLATS ON DRIVE, 2 BYPASS NIPPLES, FRONT FACING OFA, WITH CAM SENSOR HOLE	RM *
TC181F	BUICK	CAR	231	3.8	89-90	25532382, 25533497	2 FLATS ON DRIVE, 2 BYPASS NIPPLES, FRONT FACING OFA, WITHOUT CAM SENSOR HOLE	RM *
TC181G	BUICK	CAR	231	3.8	93-95	24502348, 24503274		RM *
TCV8RR	BUICK		300	4.9	65-66			RM *
TCV8RR	BUICK		340	5.6	66-67			RM *
TCV8RR	BUICK		350	5.7	68-76			RM *
TC173A	CHEV	S10	173	2.8	82-86	14100617, 12509037	FOR GOODWRENCH ENGINE	N
TC173B	CHEV	BLAZER, CAMARO, S10, F BIRD	173	2.8	87-92	14090537, 10049009		N
TC173C	CHEV	BLAZER, CAMARO, S10, F BIRD	173	2.8	82-86	14024263, 14033526, 14048323		N
TC181N	CHEV	MARINE- IND	181	3.0	63-89	3923456, 5934141A1, 49951	INDUSTRIAL & MARINE	N
TC173B	CHEV	CAMARO, FIREBIRD	189	3.1	90-92	14090537, 10049009		N
TC262P	CHEV	CAR & TRUCK	262	4.3	96-03	12554555, 12554557	W/ OPEN SENSOR HOLE (INCL. PLUG)	N
TCC350	CHEV	CAR & TRUCK	305	5.0	79-79	10243963	METAL FOR 8" BALANCER	N
TCC305	CHEV	CAR & TRUCK	305	5.0	80-95	12531283, 12523974	METAL FOR 6-3/4" BALANCER	N
TC350M	CHEV	MARINE	305	5.0	86-95		METAL FOR 6-3/4" BALANCER	N
TM350M	CHEV	MARINE	305	5.0	86-95		TIMING MARKER - METAL FOR 6-3/4" BALANCER	N
TC350C	CHEV	CAR & TRUCK	305	5.0	79-95		CHROME	N
TM350C	CHEV	CAR & TRUCK	305	5.0	79-95		CHROME TIMING MARKER	N
TC350P	CHEV	CAR & TRUCK	305	5.0	96-02	12558343, 12562818	W/OPEN SENSOR HOLE (INCL. PLUG)	N

Types of timing covers
 N = New R = Reclaimed
 RM = Remanufactured

TIMING COVERS

PART #	MFG	VEHICLE	ENG	LITERS	YEAR	CASTING / OEM#	NOTES	TYPE
TCC350	CHEV	CAR & TRUCK	350	5.7	67-79	10243963	METAL FOR 8" BALANCER	N
TCC305	CHEV	CAR & TRUCK	350	5.7	80-96	12531283, 12523974	METAL FOR 6-3/4" BALANCER	N
TC350C	CHEV	CAR & TRUCK	350	5.7	67-95		CHROME	N
TM350C	CHEV	CAR & TRUCK	350	5.7	67-95		TIMING MARKER CHROME	N
TM350M	CHEV	CAR & TRUCK	350	5.7	67-95		TIMING MARKER METAL	N
TCC349	CHEV	CAR & TRUCK	350	5.7	UP TO 85	10243967	UNCHROMED TIMING COVER	N
TC350M	CHEV	MARINE 350	5.7		86-95		TIMING MARKER - METAL FOR 6-3/4" BALANCER	N
TM350M	CHEV	MARINE 350	5.7		86-95		UNCHROMED TIMING MARKER	N
TC350P	CHEV	CAR & TRUCK	350	5.7	96-02	12558343, 12562818	W/ OPEN SENSOR HOLE (INCL. PLUG)	N
TC350P	CHEV	MARINE 350	5.7		96-02	12558343, 12562818	W/ OPEN SENSOR HOLE (INCL. PLUG)	N
TCC350	CHEV	CAR & TRUCK	400	6.6	70-80	10243963	METAL FOR 8" BALANCER	N
TC350C	CHEV	CAR & TRUCK	400	6.6	70-80		CHROME	N
TCC454	CHEV	CAR & TRUCK	396	6.5	65-70	3885048, 330850	METAL - BLACK PAINTED	N
TC454C	CHEV	CAR & TRUCK	396	6.5	65-70	3885048, 330850	CHROME	N
TM454C	CHEV	CAR & TRUCK	396	6.5	65-70	3885048, 330850	TIMING MARKER CHROME	N
TCC454	CHEV	CAR & TRUCK	427	7.0	68-90	3885048, 330850	METAL - BLACK PAINTED	N
TC454C	CHEV	CAR & TRUCK	427	7.0	68-90	3885048, 330850	CHROME	N
TM454C	CHEV	CAR & TRUCK	427	7.0	68-90	3885048, 330850	TIMING MARKER CHROME	N
TCC454	CHEV	CAR & TRUCK	454	7.4	68-90	3885048, 330850	METAL - BLACK PAINTED	N
TC454C	CHEV	CAR & TRUCK	454	7.4	68-90	3885048, 330850	CHROME	N
TM454C	CHEV	CAR & TRUCK	454	7.4	68-90	3885048, 330850	TIMING MARKER CHROME	N
TC202R	CHRY	Caravan, Dynasty, Imperial, New Yorker Town & Country, Voyager	201	3.3	90-97	4448877		RM
TC202R	CHRY	Caravan, Dynasty, Imperial, New Yorker Town & Country, Voyager	231	3.8	94-00	4448877		RM
TC318N	CHRY	TRUCK 239	3.9		87-91	2951698, 3769966	3-3/16" SEAL HOLE	N
TC318CR	CHRY	CAR, TRK & VAN	239	3.9	92-96	53006705		R *
TC318DR	CHRY	CAR, TRK & VAN	239	3.9	97-99	53020196		R *
TC318N	CHRY	CAR, TRK & VAN	318	5.2	70-91	2951698, 3769966	3-3/16" SEAL HOLE	N
TC318N	CHRY	CAR	340	5.6	70-73	2951698, 3769966	3-3/16" SEAL HOLE	N
TC318N	CHRY	CAR, TRK & VAN	360	5.9	70-91	2951698, 3769966	3-3/16" SEAL HOLE	N
TC318CR	CHRY	TRUCK	318	5.2	92-96	53006705		R *
TC318DR	CHRY	TRUCK	318	5.2	97-99	53020196		R *
TC318E	CHRY		360	5.9	90-93	4483753		R *
TC318CR	CHRY	TRUCK	360	5.9	92-96	53006705		R *
TC318DR	CHRY	TRUCK	360	5.9	97-99	53020196		R *
TC488A	CHRY	TRUCK	488	8.0	94-97	53005820, 53020971	PRESSURE RELIEF VALVE IS ON LEFT SIDE OF COVER	R *
TC488B	CHRY	TRUCK	488	8.0	98-03	53006826	CASTING 53006826 CAN BE USED FOR 53005820 & 53020971	R *
TC141I	FORD	TRUCK	122	2.0	74-88	D4FZ6019C, E3ZZ6019B	PLASTIC - INNER	N
TC141I	FORD	CAR & TRUCK	140	2.3	74-88	D4FZ6019C, E3ZZ6019B	PLASTIC - INNER	N
TC142I	FORD	CAR & TRUCK	140	2.3	89-94	F3ZZ6019B, F8DZ6019AA	PLASTIC - INNER/SENSOR LOW LEFT, BELT TENSIONER LEFT	N
TC183A	FORD	Aerostar, SABLE, TAURUS	183	3.0	86-90	E6AE6059AE, E9DE		R *
TC183B	FORD	Aerostar, SABLE, TAURUS	183	3.0	90-92	F1DE6059HA		R *
TC183CC	FORD	CAR & TRUCK	183	3.0	93-94	F3DE		R *
TC183C	FORD	RANGER, TAURUS, SABLE	183	3.0	93-94	F5DE	WITH ECC MOUNT	R *
TC232A	FORD	CAR & TRUCK	232	3.8	82-85	E2AE6059DC	W/ MECH. FUEL PUMP MOUNT	RM *
TC232B	FORD	CAR & TRUCK	232	3.8	86-87	E4AE6059B	W/ ELECT. FUEL PUMP MOUNT	RM *
TC232C	FORD	CAR & TRUCK	232	3.8	88-93	E7DE6059FA, D9DE6059BB		RM *
TC232D	FORD	CAR & TRUCK	232	3.8	94-95	F46E6059BA	WITH ECC MOUNT	RM *
TC232EN	FORD	CAR & TRUCK	232	3.8	96-99	F65E6059AE, F65E6E008AD, F65AD, F75E6F008AA, F75AED	COMPLETE WITH OIL PUMP	N

* NOTE: Reman and Reclaimed products subject to availability

Types of timing covers
 N = New R = Reclaimed
 RM = Remanufactured

TIMING COVERS

PART #	MFG	VEHICLE	ENG.	LITERS	YEAR	CASTING / OEM#	NOTES	TYPE
TC300N	FORD	TRUCK & VAN	240	3.9	65-97	E5TE6019H		N
TC244R	FORD	EXPLORER, MOUNTAINEER RANGER.	244	4.0	90-03	97JA6059A1A, 1L2E6059A4A		R *
TC232EN	FORD	CAR & TRUCK	256	4.2	97-05	F65E6059AE, F65E6E008AD, F65AD, F75E6F008AA, F75AED	COMPLETE WITH OIL PUMP	N
TC300N	FORD	TRK & VAN	300	4.9	65-97	E5TE6019H		N
TM351A	FORD	CAR, TRK & VAN	302	5.0	69-84	F1TZ6023A	BOLT ON TIMING MARKER	N
TC351A	FORD	CAR, TRK & VAN	302	5.0	69-84	D40E, D7AE, D9TE		N
TC351C	FORD	TRUCK & VAN	302	5.0	83-86	E0AE, E3AE6059CA	WITH ECC MOUNT	N
TC351C	FORD	CAR	302	5.0	83-89	E0AE, E3AE6059CA	WITH ECC MOUNT	N
TC351E	FORD	COUGAR, TBIRD	302	5.0	91-93	E5AE, E8AE	WITH ELECTRIC FUEL PUMP MOUNT	N
TC351F	FORD	TRUCK & VAN	302	5.0	87-97	E7TE6059BA, F6TE6059NA		N
TC351H	FORD	EXPLORER, MOUNTAINEER	302	5.0	96-01	F67Z6019AA, F1SE6059BC, F87E6059AA		N
TC351H	FORD	MUSTANG	302	5.0	94-95	F67Z6019AA, F1SE6059BC, F87E6059AA		N
TM351A	FORD	CAR, TRK & VAN	351W	5.8	69-84	F1TZ6023A	BOLT ON TIMING MARKER	N
TC351A	FORD	CAR, TRK & VAN	351W	5.8	69-84	D40E, D7AE, D9TE		N
TC351C	FORD	TRUCK & VAN	351W	5.8	83-86	E0AE, E3AE6059CA	WITH ECC MOUNT	N
TC351C	FORD	CAR	351W	5.8	83-89	E0AE, E3AE6059CA	WITH ECC MOUNT	N
TC351F	FORD	TRUCK & VAN	351W	5.8	87-97	E7TE6059BA, F6TE6059NA		N
DT460	FORD	CAR, TRK & VAN	429	7.0	69-78	C8SZ6754A	DIPSTICK TUBE	N
TC460N	FORD	CAR, TRK & VAN	429	7.0	69-78	E8TE6059AA		N
TC460N	FORD	TRUCK & VAN	460	7.5	69-97	E8TE6059AA		N
DT460	FORD	TRUCK & VAN	460	7.5	69-97	C8SZ6754A	DIPSTICK TUBE	N
TC460C	FORD	TRUCK & VAN	460	7.5	69-97	F6TZ6019MA	CALIFORNIA EMISSIONS -	N
TC173B	ISUZU	TROOPER	173	2.8	89-91	14090537, 10049009		N
TC173B	ISUZU	RODEO	173	2.8	89-91	14090537, 10049009		N
TC173B	ISUZU	RODEO	189	3.1	91-92	14090537, 10049009		N
TC173B	ISUZU	PICKUP	189	3.1	91-94	14090537, 10049009		N
TC173B	ISUZU	TROOPER	189	3.1	91-94	14090537, 10049009		N
TC231J	CHRYSLER	WRANGLER	230	3.8	07-11	04666020AA, OEM # 68003438AC, 68003438AA, 68003438AB		
TC361N	JEEP		290	4.7	66-69	J8129373, 3226242		N
TC361N	JEEP		304	5.0	70-81	J8129373, 3226242		N
TC361N	JEEP		343	5.6	67-69	J8129373, 3226242		N
TC361N	JEEP		360	5.9	70-91	J8129373, 3226242		N
TC361N	JEEP		390	6.4	38-70	J8129373, 3226242		N
TC361N	JEEP		401	6.6	70-78	J8129373, 3226242		N
TC400N	PONTIAC	CAR	301	4.9	69-77		W/ WATER PUMP BACKING PLATE & (2) WATER TUBE INSERTS	N
TC400N	PONTIAC	CAR	350	5.7	69-77		W/WATER PUMP BACKING PLATE & (2) WATER TUBE INSERTS	N
TC400N	PONTIAC	CAR	400	6.6	69-77		W/ WATER PUMP BACKING PLATE & (2) WATER TUBE INSERTS	N
TC400N	PONTIAC	CAR	455	7.5	70-76		W/ WATER PUMP BACKING PLATE & (2) WATER TUBE INSERTS	N
TC22RN	TOYOTA	TRUCK	22REC	2.4	85-96	11302-35010	11-1/8" TALL	N

PUSH ROD COVER/SIDE PLATES

PART #	MFG	VEHICLE	ENG.	LITERS	YEAR	CASTING / OEM#	NOTES
SP181N	CHEV	CAR, TRUCK, MARINE & INDUSTRIAL	153	2.5	ALL	93423830 / 59341A1	
SP181N	CHEV	CAR, TRUCK, MARINE & INDUSTRIAL	181	3.0	ALL	93423830 / 59341A1	
FSP300N	FORD	TRUCK & INDUSTRIAL	240	4.9	65 -74	E7TZ-6519-A, E5TZ-6519-B, C5AZ-6519-C, C5AZ-6519-B	
FSP300N	FORD	TRUCK & INDUSTRIAL	300	4.9	65 -96	E7TZ-6519-A, E5TZ-6519-B, C5AZ-6519-C, C5AZ-6519-B	

HEAD BOLTS

PART #	TTY	MFG	LITERS	CID	YEARS	NOTES
HB181N	Y	BUICK	3.0	181	85-88	
HB231N	Y	BUICK	3.3	204	89-93	
HB233N	Y	BUICK	3.8	231	86-88	VIN. 3
HB231N	Y	BUICK	3.8	231	86-95	VIN. L, C 1
HB123N		CHEVROLET	2.0	121	87-89	OHV ALUM HEAD
HB133N	Y	CHEVROLET	2.2	134	90-99	OHV ALUM HEAD
HB173N		CHEVROLET	2.8	173	80-86	
HB189N	Y	CHEVROLET	2.8	173	86-94	VIN. W
HB189N	Y	CHEVROLET	3.1	189	86-94	VIN. T, W EXCEPT CAVALIER
HB190N	Y	CHEVROLET	3.1	189	94-96	VIN. M
HB207N	Y	CHEVROLET	3.1	189	96-01	VIN. J
HB207N	Y	CHEVROLET	3.4	207	00-01	VIN. E
HB262N		CHEVROLET	4.3	262	85-97	WITHOUT SHOULDER
HB263N		CHEVROLET	4.3	262	97-06	WITH SHOULDER
HB350N		CHEVROLET	4.6	283	57-67	SMALL BLOCK V8
HB349N	Y	CHEVROLET	4.8	294	99-03	TRUCK
HB350N		CHEVROLET	5.0	305	66-97	SMALL BLOCK V8
HB350P		CHEVROLET	5.0	305		180,000 PSI MATERIAL / 1/2' HEAD
HB305N		CHEVROLET	5.0	305	96-01	
HB350N		CHEVROLET	5.3	327	62-69	SMALL BLOCK V8
HB349N	Y	CHEVROLET	5.3	325	99-03	
HB350P		CHEVROLET	5.7	350		180,000 PSI MATERIAL / 1/2' HEAD
HB350N		CHEVROLET	5.7	350	66-97	SMALL BLOCK V8 - 5/8" HEX HEAD
HB305N		CHEVROLET	5.7	350	96-01	SMALL BLOCK V8 - 1/2" HEAD
HB349N	Y	CHEVROLET	5.7	346	97-03	
HB454N		CHEVROLET	6.0	366	66-94	BIG BLOCK V8
HB349N	Y	CHEVROLET	6.0	364	99-03	
HB381N		CHEVROLET	6.2	381	82-93	DIESEL
HB454N		CHEVROLET	6.5	396	70-72	BIG BLOCK V8
HB381N		CHEVROLET	6.5	395	92-01	DIESEL
HB350N		CHEVROLET	6.6	400	66-97	SMALL BLOCK V8
HB454N		CHEVROLET	7.0	427	66-94	BIG BLOCK V8
HB454N		CHEVROLET	7.4	454	70-98	BIG BLOCK V8
HB496N		CHEVROLET	8.1	496	01-08	
HB454N		CHEVROLET	8.2	502	90-98	
HB143N		CHRYSLER	2.0	2000CC	95-00	SOHC VIN. C
HB145N		CHRYSLER	2.0	2000CC	95-00	DOHC VIN. Y
HB121N		CHRYSLER	2.0			4G63
HB134N	Y	CHRYSLER	2.2	135	81-85	10MM
HB135N	Y	CHRYSLER	2.2	135	86-94	11MM
HB121N		CHRYSLER	2.4			4G64
HB135N		CHRYSLER	2.5	153	86-95	11MM
HB156N		CHRYSLER	2.6	2600CC	81-90	
HB166N		CHRYSLER	2.7	166	98-04	DOHC VIN. R, VIN. U
HB180N		CHRYSLER	3.0	181	87-96	
HB197N	Y	CHRYSLER	3.2	197	98-01	CONCORD SOHC VIN. J
HB202N	Y	CHRYSLER	3.3	201	90-01	
HB196N		CHRYSLER	3.5	215	93-97	
HB197N	Y	CHRYSLER	3.5	215	98-04	CONCORD SOHC VIN. G
HB226N		CHRYSLER	3.7	226	02-12	
HB202N	Y	CHRYSLER	3.8	231	90-01	
HB287N		CHRYSLER	4.7	287	99-10	
HB239N		CHRYSLER	3.9	239	92-03	VIN. X MAGNUM
HB318N		CHRYSLER	5.2	318	92-04	
HB318N		CHRYSLER	5.9	360	92-03	
HB149N		DODGE	2.5	150	98-02	DAKOTA
HB318N		DODGE	5.2	318	92-04	
HB318N		DODGE	5.9	360	92-03	

HEAD BOLTS

PART #	TTY	MFG	LITERS	CID	YEARS	NOTES
HB098N	Y	FORD	1.6	98	81-85	
HB098N	Y	FORD	1.9	116	85-96	
HB098N	Y	FORD	2.0	122	97-01	SOHC VIN. P TRACER / ESCORT
HB140N		FORD	2.3	140	74-97	OHC
HB141N		FORD	2.3	140	84-92	HSC
HB141N		FORD	2.5	153	84-92	HSC
HB171N		FORD	2.8	171	76-87	CAR & TRUCK
HB177N	Y	FORD	2.9	177	86-90	
HB183N		FORD	3.0	183	86-98	VIN. U
HB184N	Y	FORD	3.0	183	89-95	S.H.O. VIN Y
HB185N		FORD	3.0	183	99-04	DOHC
HB230N	Y	FORD	3.8	232	82-88	
HB184N	Y	FORD	3.2	195	93-95	DOHC VIN. P
HB232N	Y	FORD	3.8	232	89-95	
HB256N	Y	FORD	3.8	232	96-01	
HB256N	Y	FORD	3.9	238	04-07	OHV VIN. 4
HB177N	Y	FORD	4.0	244	90-01	
HB256N	Y	FORD	4.2	256	96-04	VIN. 2
HB280N	Y	FORD	4.6	250	91-04	SOHC / DOHC
HB302N	Y	FORD	5.0	302	70-01	
HB280N	Y	FORD	5.4	330	97-04	SOHC
HB370N		FORD	6.1	370	79-91	TRUCK VIN. H
HB413N		FORD	6.8	413	97-03	V10 VIN. S
HB370N		FORD	7.0	429	79-91	TRUCK
HB370N		FORD	7.5	460	68-99	VIN. L / G
HB061N	Y	GEO	1.0	61	85-92	SPRINT 3 CYL
HB097N	Y	GEO	1.6	98	89-95	G16KC (SUZUKI ENGINE)
HB150N		JEEP	2.456	150	83-96	1/2" BOLTS -head casting 403 or 117
HB149N	Y	JEEP	2.5	150	97-02	TJ, Wrangler, Grand Cherokee, Cherokee
HB226N		JEEP	3.7	226	02-12	Liberty, Grand Cherokee
HB259N		JEEP	4.0	242	86-96	1/2" BOLTS -
HB244N		JEEP	4.0	244	96-06	TJ, Wrangler, Grand Cherokee, Cherokee
HB259N		JEEP	4.2	258	86-96	1/2" BOLTS -
HB287N		JEEP	4.7	287	99-09	Dakota, Ram, Durango, Commander, Grand Cherokee, Aspen
HB177N		MAZDA	4.0	4015CC	91-00	VIN. X, 8X, ZYL (OHC)
HB121N		MITSUBISHI	2.0	122	4G63	M11 x 1.25 x 118 with captured washer
HB121N		MITSUBISHI	2.4	143	4G64	M11 x 1.25 x 118 with captured washer
HB156N		MITSUBISHI	2.6	2600CC	81-90	
HB180N		MITSUBISHI	3.0	181	87-96	
HB143N		NEON	2.0	2000CC	95-00	SOHC
HB145N		NEON	2.0	2000CC	95-00	DOHC
HB142N	Y	OLDSMOBILE	2.3	138	88-96	QUAD 4 DOHC VIN. A, D
HB142N	Y	OLDSMOBILE	2.3	138	92-94	QUAD OHC VIN. 3
HB122N		PONTIAC	1.8	112	82-86	VIN. O, J
HB122N		PONTIAC	2.0	122	87-94	VIN. H, K, M
HB151N		PONTIAC	2.5	151	80-83	
HB153N		PONTIAC	2.5	151	85-91	VIN. U
HB199N	Y	TOYOTA	2.0	1988CC	87-89	CAMRY 3SFE
HB216N	Y	TOYOTA	2.2	2164CC	90-01	CAMRY 5SFE
HB144N		TOYOTA	2.4	2366CC	85-96	22REC
HB179N	Y	TOYOTA	3.0	2959CC	88-95	3VZE SOHC
HB206N		TOYOTA	3.4	3377CC	95-01	5VZE TRUCK

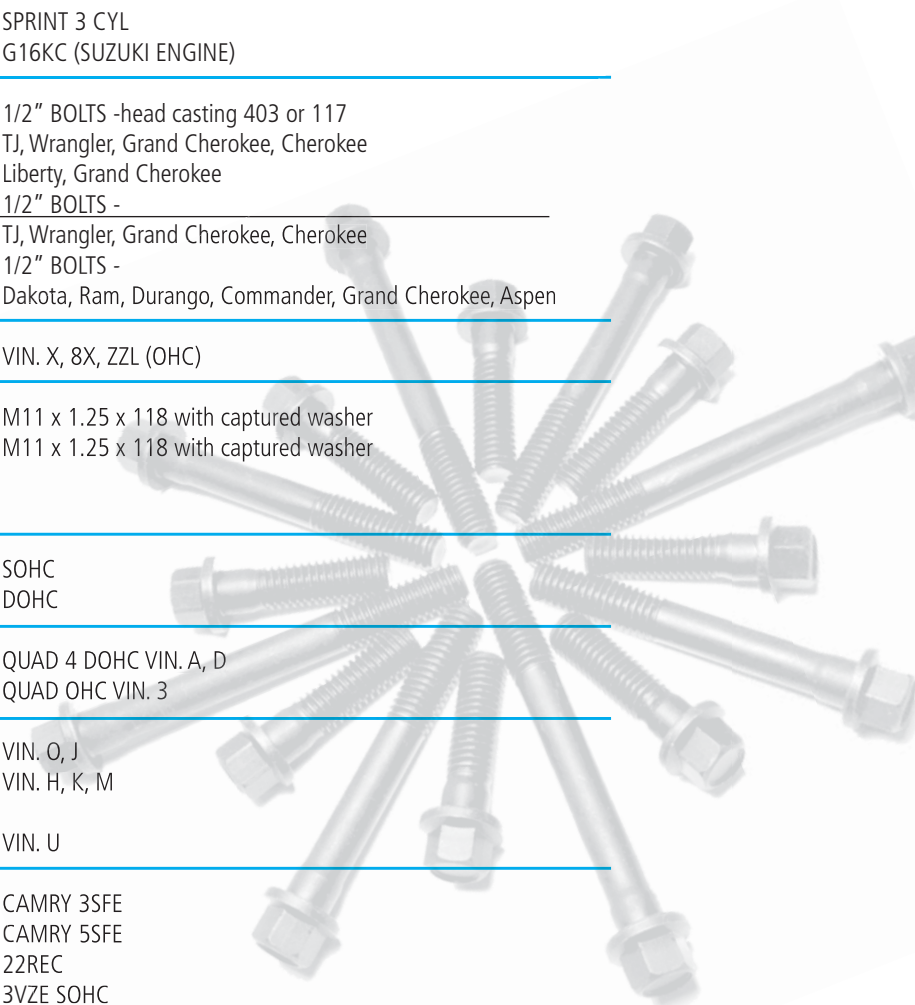

PART #	ENG. MFG	CID	LITER	YEAR	NOTES	CROSS REFERENCE
VALVE COVERS/ROCKER COVERS						
VC262	Chevrolet	262	4.3	1985-93	METAL	14252, 814504
VC350M	Chevrolet	305	5.0	1970-85	METAL, Outer bolt down holes 1 push-in hole & 1 turn-in cap hole	523331A1, 58211, 79961, 79961T1
VC350M	Chevrolet	350	5.7	1970-85	METAL, Outer bolt down holes 1 push-in hole & 1 turn-in cap hole	523331A1, 58211, 79961, 79961T1
VC351L	Chevrolet	305	5.0	1986-96	METAL, Center bolt down holes 1 push-in & 1 screw-in, 1 push-in	
VC351L	Chevrolet	350	5.7	1986-96	METAL, Center bolt down holes 1 push-in & 1 screw-in, 1 push-in	
VC352L	Chevrolet	305	5.0	1986-96	METAL, Center bolt down holes 1 push-in & 1 screw-in	809995
VC352L	Chevrolet	350	5.7	1986-96	METAL Center bolt down holes 1 push-in & 1 screw-in	809995
VC454	Chevrolet	427	7.0	1969-74	METAL	17671
VC454	Chevrolet	454	7.4	1969-90	METAL	17671
CAPS and GROMMETS						
OC350N	Chevrolet			Universal	Oil Filler Cap Universal Screw-In	36-18710002 38-18710
PCV350	Chevrolet			Universal	Rocker Cover / Breather Grommet Universal	23-8M007155
HARMONIC BALANCER						
BA350N	Chevrolet	262	4.3	1979-95	6-3/4" OD	75420
BA349N	Chevrolet	262	4.3	1996-98	8" OD	8524946001, 852946, 863397
BA350N	Chevrolet	305	5.0	1979-95	6-3/4" OD	75420
BA349N	Chevrolet	305	5.0	1996-98	8" OD	8524946001, 852946, 863397
BA350N	Chevrolet	350	5.7	1979-95	6-3/4" OD	75420
BA349N	Chevrolet	350	5.7	1996-98	8" OD	8524946001, 85294, 863397
BA460A	Ford	460	7.5	1968-97		
TIMING COVERS						
TC181N	Chevrolet	181	3.0	1963-89		5934141A1, 49951
TC350M	Chevrolet	262	4.3	1986-95	METAL, for use with 6-3/4" O.D. Balancer non-balance shaft engine	14249A2, 60660A1
TC262P	Chevrolet	262	4.3	1996-03	PLASTIC, Non-balance shaft engine Includes plug kit to block crank position sensor hole in cover	809893, 863396
TC351A	Ford	302	5.0	1970-74	ALUMINUM	56103
TC350M	Chevrolet	305	5.0	1986-95	METAL, for use with 6-3/4" O.D. Balancer	14249A2, 60660A1
TCC349	Chevrolet	305	5.0	1986-95	METAL, for use with 8" O.D. Balancer order TM350 marker separately	
TC350P	Chevrolet	305	5.0	1996-02	PLASTIC, Includes plug kit to block crank position sensor hole in cover	835005
TC318N	Chrysler	318	5.2	1975-85	ALUMINUM, LM318 / LM360	3619878, 4142252
TC350P	Chevrolet	350	5.7	1996-03	PLASTIC, Includes plug kit to block crank position sensor hole in cover	835005
TC350M	Chevrolet	350	5.7	1986-95	METAL, for use with 6-3/4" O.D. Balancer	14249A2, 60660A1
TCC349	Chevrolet	350	5.7	1986-95	METAL, for use with 8" O.D. Balancer order TM350 marker separately	
TC351A	Ford	351W	5.7	1973-77	ALUMINUM	56103
TC318N	Chrysler	360	5.9	1975-85	ALUMINUM, LM318 / LM360	3619878, 4142252
TCC454	Chevrolet	427	7.0	1969-74	METAL	66215
TCC454	Chevrolet	454	7.4	1968-90	METAL	66215
OIL FILTER ADAPTORS						
OFA454	Chevrolet	181	3.0		L4 - also known as connector	22-805632
OFA262	Chevrolet	262	4.3	1986-93	V6 - also known as connector	11972
OFA305	Chevrolet	305	5.0	1986-02	V8 - also known as connector	71920
OFA305	Chevrolet	350	5.7	1986-02	V8 - also known as connector	71920
OFA454	Chevrolet	454	7.4	1965/ Newer	V8 - also known as connector	22-805632
OFA454	Chevrolet	502	8.2	1996/ Newer	V8 - also known as connector	22-805632
OFA302	Ford	302	5.0	1970-90	V8 - also known as connector	22-56876
OFA460	Ford	460	7.5	1968-97	V8 - also known as connector	

MARINE COMPONENTS

PART #	ENG. MFG	CID	LITER	YEAR	NOTES	CROSS REFERENCE
OIL PAN RAILS						
OPR262	Chevrolet	262	4.3	1986-93	For use on 1 piece rear seal engine and with oil pan part # OP262M	14245 (right side) 14246 (left side)
OPR350	Chevrolet	305	5.0	1985-02	For use on 1 piece rear seal engine	14257 (port side) 14256 (starboard side)
OPR350	Chevrolet	350	5.7	1985-02	For use on 1 piece rear seal engine	14257 (port side) 14256 (starboard side)
PAN BOLT						
OPB305	Chevrolet	262	4.3	1986-93	1/4 - 20	10-14070
OPB305	Chevrolet	305	5.0	1985-02	1/4 - 20	10-14070
OPB305	Chevrolet	350	5.7	1985-02	1/4 - 20	10-14070
OIL PANS						
OP262M	Chevrolet	262	4.3	1986-93	For use on 1 piece rear seal engine	14244
OP350B	Chevrolet	305	5.0	1970-79	LEFT DIP, 6 quart. For use with bolt-in windage tray / baffle	87758A1, 47549
OP350M	Chevrolet	305	5.0	1986-96	For use on 1 piece rear seal engine 5 qt For use with bolt-in windage tray / baffle	13840A1, 805930A1
OP350N	Chevrolet	305	5.0	1989-Up	12MM Drain Plug, *For use with bolt-in windage tray / baffle	808588, 809910, 88901T
OP350B	Chevrolet	350	5.7	1970-79	LEFT DIP, 6 quart. For use with bolt-in windage tray / baffle	87758A1, 47549
OP350M	Chevrolet	350	5.7	1986-96	5 quart. For use with bolt-in windage tray / baffle	3840A1, 805930A1
OP350N	Chevrolet	350	5.7	1989-Up	12MM Drain Plug, *For use with bolt-in windage tray / baffle	808588, 889501T, 809910
OP350P	Chevrolet	350	5.7	1989-96	14MM Drain Plug, w/ baffle welded in pan *	808588*
OP350B	Chevrolet	400	6.6	1970-79	LEFT DIP, 6 quart. For use with bolt-in windage tray / baffle	87758A1, 47549
OP454	Chevrolet	427	7.0	1969-74	2 rear seal engine application	47552A5, 47552
OP454	Chevrolet	454	7.4	1965-90	2 rear seal engine application	47552A5, 47552
WINDAGE TRAY/OIL BAFFLE						
WTC350N	Chevrolet	305	5.0	1979-97	Windage tray / oil baffle	98602, 986021
WTC350N	Chevrolet	350	5.7	1979-97	Windage tray / oil baffle	98602, 986021
SBM350	Chevrolet	262	4.3	1986-93	Studded main bolt / windage tray mounting bolt	16-54790
SBM350	Chevrolet	305	5.0	1979-97	Studded main bolt / windage tray mounting bolt	16-54790
SBM350	Chevrolet	350	5.7	1979-97	Studded main bolt / windage tray mounting bolt	16-54790
HEAD BOLTS						
HB262N	Chevrolet	262	4.3	1985-1997	5/8" hex head bolt	
HB263N	Chevrolet	262	4.3	1997-2006	1/2" hex head	10-11966, 10-119671, 10-11968
HB302N	FORD	302	5.0	1970-2001	TORQUE TO YIELD	10-56112, 10-56113
HB350P	Chevrolet	305	5.0		1/2" hex head	10-11966, 10-119671, 10-11968
HB350P	Chevrolet	350	5.7		1/2" hex head	10-11966, 10-119671, 10-11968
HB350N	Chevrolet	305	5.0		5/8" hex head bolt	
HB350N	Chevrolet	350	5.7		5/8" hex head bolt	
HB454N	Chevrolet	427	7.0	1969-74	BIG BLOCK	10-8M0000463, 10-8M0000482
HB454N	Chevrolet	454	7.4	1965-90	BIG BLOCK	10-8M0000463, 10-8M0000482
HB496N	Chevrolet	496	8.1			10-881642A01 - 10-881625 10-881642A01 - 10-881624 10-881642A01 - 10-881642
HB454N	Chevrolet	502	8.2	1990-98		10-8M0000463, 10-8M0000482

PART #	ENG. MFG	CID	LITER	YEAR	NOTES	CROSS REFERENCE
CYLINDER HEADS						
CH305B	Chevrolet	305	5.0	1996 - Up	Replaces casting number: 12552520, 12557113, 12558059 Intake runner 170CC, Combust. Chamber 58CC	938-802556*
CH305BA	Chevrolet	305	5.0	1996 - Up	Replaces casting number: 12552520, 12557113, 12558059 Intake runner 170CC, Combust. Chamber 58CC ASSEMBLED	938-802556
CH318BA	Chrysler	318	5.2	1975-85	Requires changeover to 1992 318/360, Rocker Arms, & pushrods, 172cc Intake Runner - 62cc Combust. Chamber ASSEMBLED	3745351 *
CH350A	Chevrolet	350	5.7	1969-86	Universal, Intake runner 178CC, Combust. Chamber 76CC With Heat Riser / 69-86 Intake manifold bolt pattern 7 bolt hole exhaust mounting Perimeter valve cover holes	938-7499*
CH350AA	Chevrolet	350	5.7	1969-86	Universal, Intake runner 178CC, Combust. Chamber 76CC With Heat Riser / 69-86 Intake manifold bolt pattern 7 bolt hole exhaust mounting Perimeter valve cover holes ASSEMBLED	938-7499*
CH350H	Chevrolet	350	5.7	1969-86	Replaces casting number: 083, 191, 193, 217, 810, With Heat Riser / 69-86 Intake manifold bolt pattern Perimeter valve cover holes Recommended to be replaced in pairs.	
CH350HA	Chevrolet	350	5.7	1969-86	Replaces casting number: 083, 191, 193, 217, 810, With Heat Riser / 69-86 Intake manifold bolt pattern Perimeter valve cover holes Recommended to be replaced in pairs. ASSEMBLED	
CH350G	Chevrolet	350	5.7	1987-95	Replaces casting number: 083, 191, 193, 217, 810, With Heat Riser / 87-95 Intake manifold bolt pattern, Center bolt down valve cover holes Recommended to be replaced in pairs.	938-883490 1
CH350GA	Chevrolet	350	5.7	1987-95	Replaces casting number: 083, 191, 193, 217, 810, With Heat Riser / 87-95 Intake manifold bolt pattern, Center bolt down valve cover holes Recommended to be replaced in pairs. ASSEMBLED	938-883490 1
CH350C	Chevrolet	350	5.7	1996-06	Replaces casting number 12558062, 10239906, Intake runner 170CC Combustion Chamber 64CC	938-883297, 938-803860T
CH350CA	Chevrolet	350	5.7	1996-06	Replaces casting number 12558062, 10239906, Intake runner 170CC, Combustion Chamber 64CC, ASSEMBLED	938-883297 938-803860T
CH454C	Chevrolet	454	7.4	1996-00	Universal Replaces casting number 12560241, 10141279 246cc Intake Runner -100cc Combustion Chamber / Vortec Chamber (.370/.3716 valve id), Direct replacement for 1996- 2000 / When installing on 1996 and earlier models, must use Bolt Down Rocker Arms and Head Gasket by Felpro # 1017 or equivalent	938-883492R1
CH454CA	Chevrolet	454	7.4	1996-00	Replaces casting number 12560241, 10141279, 246cc Intake Runner - 100cc Combustion Chamber / Vortec Chamber (.370/.3716 valve id) ASSEMBLED	938-883492R1
CH502A	Chevrolet	502	8.2	MARINE	CAST IRON Replaces casting number 14097088 Intake runner 299CC, Combustion Chamber 118CC	938-5924, 938-814512
BLOCK OFF PLATES WITH GASKET FUEL PUMP						
BOP076	Universal				2 hole mounting	
BOP087	Chevrolet	305	5.0			
		350	5.7		4 hole mounting	807695, 809695T
BLOCK OFF PLATES GASKET FUEL PUMP						
GOP076	Universal				2 hole mounting	
GOP087	Chevrolet	305	5.0			
		350	5.7		4 hole mounting	
ROLLER LIFTER GUIDES						
RLG350	Chevrolet	350	5.7	1986 & Newer	Also known as clips	17341T
RLG454	Chevrolet	454	7.4	1996 & Newer	Also known as clips	845754, 850474
ROLLER LIFTER RETAINERS						
RLR350N	Chevrolet	305	5.0	1986-97	Also known as Spider	811662
RLR350N	Chevrolet	350	5.7	1986-97	Also known as Spider	811662

INTAKE MANIFOLD

PART #	ENG. MFG	CID	LITER	YEAR	CROSS REF.
--------	----------	-----	-------	------	------------

IN350MB	Chevrolet	305	5.0	1997-95	
IN350MB	Chevrolet	350	5.7	1997-95	
IN350MA	Chevrolet	305	5.0	1996-02	17618T
IN350MA	Chevrolet	350	5.7	1996-02	17618T

NOTES:

- 4 Barrel Universal Carburetor mounting
- 15 degree carb flange
- All required mounting and accessories holes are tapped
- Superior runner finish for increased air flow
- CNC machined for exact fit and bolt hole location
- Manufactured of the highest grade of cast iron to resist salt water corrosion that aluminum intakes experience & corrosion caused by natural gas and other dry fuels
- Electric Choke

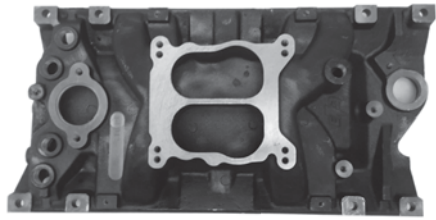



INTAKE MANIFOLD PLUG KIT

PART #	MFG	VEHICLE	ENGINE	LITERS	YEARS	NOTES
--------	-----	---------	--------	--------	-------	-------

PKIN350	CHEV	CAR, TRUCK, MARINE & INDUSTRIAL	350	5.7	ALL	ALL THE PIPE PLUGS NEEDED TO BLOCK THE THREADED HOLES IN IN350MA & IN350MB
---------	------	---------------------------------	-----	-----	-----	--



ROLLER LIFTER RETAINERS

	DESCRIPTION	YEARS	PART #	ITEM
 RLR350N	SMALL BLOCK CHEV V8	1986 - 97	RLG350	CLIP / GUIDE
	SMALL BLOCK CHEV V8	1986 - 97	RLR350N	RETAINER
	SMALL BLOCK CHEV V8	1986 - 97	RLR350KIT	RETAINER, 3 MOUNTING BOLTS, 8 CLIPS
	SMALL BLOCK CHEV V8	1987 - 90	RLRDLXA	RETAINER, 3 MOUNTING BOLTS, 8 CLIPS, CAM THRUST PLATE (4.23" T2T), CAM THRUST PLATE MOUNTING BOLTS
 RLG350	SMALL BLOCK CHEV V8	1991 - 02	RLRDLXB	RETAINER, 3 MOUNTING BOLTS, 8 CLIPS, CAM THRUST PLATE (3.900" T2T), CAM THRUST PLATE MOUNTING BOLTS
	BIG BLOCK CHEV V8		RLG454	CLIP / GUIDE



PUSH ROD COVER/SIDE PLATE

PART #	MFG	VEHICLE	ENG	LITERS	YEARS	CASTING / OEM
SP181N	CHEV	CAR, TRUCK, MARINE & INDUSTRIAL	153	2.5	ALL	93423830 / 59341A1
SP181N	CHEV	CAR, TRUCK, MARINE & INDUSTRIAL	181	3.0	ALL	93423830 / 59341A1

EQ offers bare and fully loaded cylinder heads!

All EQ cylinder heads outperform their competitors!

EQ bare heads are ready to install to the drive train-- no porting or polishing needed!

EQ loaded heads include OE quality stainless steel valves, seals, valve springs and retainers.

Contact an EQ cyl. head specialist for all the latest..., or visit us at enginequest.com

- The highest grade cast iron and aluminum
- Thicker deck for greater strength
- Improved design resists cracking
- Superior port finish for increased flow
- Water Flow redesigned for greater thermal conductivity
- Hardened exhaust seats
- CNC machined guides and seats
- 25 point quality check on every head
- 3 angle valve finish
- Competitive pricing

PART #	CID	LITER	YEARS	NOTES
AMC /JEEP				
CH150N	150	2.5	1987 - 2002	REPLACES CASTING NUMBERS: 2403, 117 1/2' HEAD BOLT
CH150NA	150	2.5	1987 - 2002	REPLACES CASTING NUMBERS: 2403, 117 1/2' HEAD BOLT ASSEMBLED
CH226LN	225	3.7	2002 - 2004	LEFT HEAD / DRIVERS SIDE, REPLACES CASTING NUMBERS: 53020983, 53020983AB WITH EGR HOLE. BLOCK-OFF KIT INCLUDED
CH226RN	225	3.7	2002 - 2004	RIGHT HEAD / PASSENGER SIDE, REPLACES CASTING NUMBERS: 53020984, 53020984AB
CH227LN	225	3.7	2005 - 2012	LEFT HEAD / DRIVERS SIDE, REPLACES CASTING NUMBERS: 53020983AD, 53020983AC WITH EGR HOLE. BLOCK-OFF KIT INCLUDED
CH227RN	225	3.7	2005 - 2012	RIGHT HEAD / PASSENGER SIDE, REPLACES CASTING NUMBERS: 53020984AC
CH242N	242	4.0	1998 - 2006	331 CASTING
CH242NA	242	4.0	1998 - 2006	331 CASTING - ASSEMBLED
CH281LN	287	4.7	1999 - 2008	LEFT HEAD / DRIVERS SIDE, REPLACES CASTING NUMBERS: 53020801AC, 53020803
CH281RN	287	4.7	1999 - 2008	RIGHT HEAD / PASSENGER SIDE, REPLACES CASTING NUMBERS: 53020802, 53020804
CH318A	318	5.2	1992 - 2003	REPLACES CASTING NUMBERS: 53005714, 53006671, 53020466, 53020468 172CC INTAKE RUNNER - 62CC COMBUSTION CHAMBER
CH318AA	318	5.2	1992 - 2003	REPLACES CASTING NUMBERS: 53005714, 53006671, 53020466, 53020468 172CC INTAKE RUNNER - 62CC COMBUSTION CHAMBER , ASSEMBLED
CHEVROLET				
CH134N	134	2.2	1990 - 1997	391 / 391S - 7MM VALVE GUIDE ID
CH134NA	134	2.2	1990 - 1997	391 / 391S - ASSEMBLED
CH151N	151	2.5	1989 - 1991	10044642 CAST IRON
CH305B	305	5.0	1996 - 2002	REPLACES CASTING NUMBERS:12552520, 12557113, 12558059, INTAKE RUNNER 170CC, COMBUSTION CHAMBER 58CC, ANGLE SPARK PLUG
CH305BA	305	5.0	1996 - 2002	REPLACES CASTING NUMBERS:12552520, 12557113, 12558059, INTAKE RUNNER 170CC, COMBUSTION CHAMBER 58CC, ANGLE SPARK PLUG ASSEMBLED
CH350A	350	5.7	1955 - 1986	UNIVERSAL INTAKE RUNNER 178CC , COMBUSTION CHAMBER 76CC WITH HEAT RISER / 69-86 INTAKE MANIFOLD BOLT PATTERN, 7 BOLT HOLE EXHAUST MOUNTING, ANGLE SPARK PLUG, PERIMETER VALVE COVER MOUNTING HOLES
CH350AA	350	5.7	1955 - 1986	UNIVERSAL INTAKE RUNNER 178CC, COMBUSTION CHAMBER 76CC WITH HEAT RISER / 69-86 INTAKE MANIFOLD BOLT PATTERN, 7 BOLT HOLE EXHAUST MOUNTING, ANGLE SPARK PLUG, PERIMETER VALVE COVER HOLES, ASSEMBLED
CH350H	350	5.7	1969 - 1986	REPLACES CASTING NUMBER:14101083, 14096217, 14102191, 14102193, INTAKE RUNNER 176CC, COMBUSTION CHAMBER 64CC VORTEC STYLE WITH HEAT RISER / 69-86 INTAKE MANIFOLD BOLT PATTERN, PERIMETER VALVE COVER HOLES, ANGLE SPARK PLUG, RECOMMENDED TO BE REPLACED IN PAIRS.
CH350HA	350	5.7	1969 - 1986	REPLACES CASTING NUMBER:14101083, 14096217, 14102191, 14102193, INTAKE RUNNER 176CC, COMBUSTION CHAMBER 64CC VORTEC STYLE WITH HEAT RISER / 69-86 INTAKE MANIFOLD BOLT PATTERN, PERIMETER VALVE COVER HOLES, ANGLE SPARK PLUG RECOMMENDED TO BE REPLACED IN PAIRS. ASSEMBLED

CYLINDER HEADS

PART #	CID	LITER	YEARS	NOTES
CHEVROLET <i>cont.</i>				
CH350G	350	5.7	1987 - 1995	REPLACES CASTING NUMBER:14101083, 14096217, 14102191, 14102193, INTAKE RUNNER 176CC, COMBUSTION CHAMBER 64CC VORTEC STYLE WITH HEAT RISER / 87 95 INTAKE MANIFOLD BOLT PATTERN, CENTER BOLT DOWN VALVE COVER HOLES ANGLE SPARK PLUG, RECOMMENDED TO BE REPLACED IN PAIRS.
CH350GA	350	5.7	1987 - 1995	REPLACES CASTING NUMBER: 14101083, 14096217, 14102191, 14102193, INTAKE RUNNER 176CC, COMBUSTION CHAMBER 64CC VORTEC STYLE WITH HEAT RISER / 87 95 INTAKE MANIFOLD BOLT PATTERN, CENTER BOLT DOWN VALVE COVER HOLES ANGLE SPARK PLUG RECOMMENDED TO BE REPLACED IN PAIRS. ASSEMBLED
CH350C	350	5.7	1996 - 2006	REPLACES CASTING NUMBER 12558062, 10239906, INTAKE RUNNER 170CC COMBUSTION CHAMBER 64CC,STRAIGHT SPARK PLUG
CH350CA	350	5.7	1996 - 2006	REPLACES CASTING NUMBER 12558062, 10239906, INTAKE RUNNER 170CC COMBUSTION CHAMBER 64CC, STRAIGHT SPARK PLUG. ASSEMBLED
CH350I	350	5.7	PERFORM.	IMCA SANCTIONED SPORT MOD HEAD INTAKE RUNNER 178CC, COMBUSTION CHAMBER 76CC 69-86 INTAKE MANIFOLD BOLT PATTERN,7 BOLT HOLE EXHAUST MOUNTING PERIMETER VALVE COVER HOLES, WITH HEAT RISER
CHLSBLNK				LS PORTER BLANK
CH395N	381	6.2	1990 - 1995	10137567 -90° INTAKE BOLTS
CH395B	395	6.5	1992 - 1999	10137567 -60° INTAKE BOLTS
CH395N	395	6.5	1992 - 1999	10137567 -90° INTAKE BOLTS
CH402A	402	6.6	2004 - 2006	DURAMAX - VIN 2 LLY
CH402B	402	6.6	2006 - 2007	DURAMAX - VIN D LBZ
CH454A	454	7.4	PERFORM.	RECTANGULAR PORT-INTAKE RUNNER 320CC, COMBUSTION CHAMBER 119CC
CH454B	454	7.4	PERFORM.	RECTANGULAR PORT-INTAKE RUNNER 360CC, COMBUSTION CHAMBER 119CC
CH454C	454	7.4	1996 - 2000	UNIVERSAL REPLACES CASTING NUMBER 12560241, 10141279, 246CC INTAKE RUNNER 100CC COMBUSTION CHAMBER / VORTEC CHAMBER (.370/.3716 VALVE ID) DIRECT REPLACEMENT FOR 1996- 2000 / WHEN INSTALLING ON 1996 AND EARLIER MODELS, MUST USE BOLT DOWN ROCKER ARMS AND HEAD GASKET BY FELPRO # 1017 OR EQUIV.
CH454CA	454	7.4	1996 - 2000	REPLACES CASTING NUMBER 12560241, 10141279,246CC INTAKE RUNNER, 100CC COMBUSTION CHAMBER / VORTEC CHAMBER (.370/.3716 VALVE ID) DIRECT REPLACEMENT FOR 1996- 2000. ASSEMBLED
CH502A	502	8.2	MARINE / PERFORM.	CAST IRON REPLACES CASTING # 14097088, INTAKE RUNNER 299CC, COMBUSTION CHAMBER 118CC
CHRYSLER				
CH123N	1997	2.0	1983 - 1991	4G63 12 VALVE WITH FUEL PUMP HOLE
CH124N	1997	2.0	1990 - 1992	4G63 - 8 VALVE WITH FUEL PUMP HOLE
CH124NA	1997	2.0	1990 - 1992	4G63 - 8 VALVE WITH FUEL PUMP HOLE ASSEMBLED
CH143A	2350	2.4	1993 - 1999	4G64 - 8 VALVE - SOHC
CH143AA	2350	2.4	1993 - 1999	4G64 - 8 VALVE - SOHC ASSEMBLED
CH154N	2555	2.6	1981 - 1990	4G54B 8 VALVE - SOHC
CH226LN	225	3.7	2002 - 2004	LEFT HEAD / DRIVERS SIDE REPLACES CASTING NUMBERS: 53020983, 53020983AB WITH EGR HOLE. BLOCK-OFF KIT INCLUDED
CH226RN	225	3.7	2002 - 2004	RIGHT HEAD / PASSENGER SIDE REPLACES CASTING NUMBERS: 53020984, 53020984AB
CH227LN	225	3.7	2005 - 2012	LEFT HEAD / DRIVERS SIDE REPLACES CASTING NUMBERS: 53020983AD, 53020983AC WITH EGR HOLE. BLOCK-OFF KIT INCLUDED
CH227RN	225	3.7	2005 - 2012	RIGHT HEAD / PASSENGER SIDE REPLACES CASTING NUMBERS: 53020984AC
CH281LN	287	4.7	1999 - 2008	LEFT HEAD / DRIVERS SIDE REPLACES CASTING NUMBERS: 53020801AC, 53020803 WITH EGR HOLE. BLOCK-OFF KIT INCLUDED
CH281RN	287	4.7	1999 - 2008	RIGHT HEAD / PASSENGER SIDE REPLACES CASTING NUMBERS: 53020802, 53020804
CH318A	318	5.2	1992 - 2003	REPLACES CASTING NUMBERS: 53005714, 53006671, 53020466, 53020468 172CC INTAKE RUNNER - 62CC COMBUSTION CHAMBER
CH318AA	318	5.2	1992 - 2003	REPLACES CASTING NUMBERS: 53005714, 53006671, 53020466, 53020468 172CC INTAKE RUNNER - 62CC COMBUSTION CHAMBER. ASSEMBLED
CH318B	318	5.2	PERFORM.	WITH LA STYLE INTAKE BOLT PATTERN REPLACES CASTING NUMBERS: 53005714, 53006671, 53020466, 53020468, 172CC INTAKE RUNNER - 62CC COMBUSTION CHAMBER
CH318BA	318	5.2	PERFORM.	WITH LA STYLE INTAKE BOLT PATTERN REPLACES CASTING NUMBERS: 53005714, 53006671, 53020466, 53020468, 172CC INTAKE RUNNER - 62CC COMBUSTION CHAMBER ASSEMBLED
CH318A	360	5.9	1992 - 2003	REPLACES CASTING NUMBERS: 53005714, 53006671, 53020466, 53020468, 172CC INTAKE RUNNER -62CC COMBUSTION CHAMBER
CH318AA	360	5.9	1992 - 2003	REPLACES CASTING NUMBERS: 53005714, 53006671, 53020466, 53020468, 172CC INTAKE RUNNER - 62CC COMBUSTION CHAMBER. ASSEMBLED

PART # CID LITER YEARS NOTES

CHRYSLER *cont.*

CH318B	360	5.9	PERFORM.	WITH LA STYLE INTAKE BOLT PATTERN REPLACES CASTING NUMBERS: 53005714, 53006671, 53020466, 53020468, 172CC INTAKE RUNNER - 62CC COMBUSTION CHAMBER
CH318BA	360	5.9	PERFORM.	WITH LA STYLE INTAKE BOLT PATTERN REPLACES CASTING NUMBERS: 53005714, 53006671, 53020466, 53020468, 172CC INTAKE RUNNER - 62CC COMBUSTION CHAMBER - ASSEMBLED
CH359N	359	5.9	1999 - 2002	4V VALVE L6 DIESEL CASTING # 3943627 / 6BT CUMMINS - DESIGNED TO USE WITH NON-SLOTTED TYPE INJECTORS

FORD

CH121N	121	2.0	2000 - 2003	YS4E-EA - SOHC
CH121NA	121	2.0	2000 - 2003	4YSE-EA - SOHC - ASSEMBLED
CH140A	140	2.3	1995 - 1997	REPLACES CASTING NUMBERS: F57E, F87E, F5JL, DUAL SPARK PLUG
CH140AA	140	2.3	1995 - 1997	REPLACES CASTING NUMBERS: F57E, F87E, F5JL, DUAL SPARK PLUG - ASSEMBLED
CH140A	152	2.5	1998 - 2001	REPLACES CASTING NUMBERS: F57E, F87E, F5JL, DUAL SPARK PLUG
CH140AA	140	2.3	1995 - 1997	REPLACES CASTING NUMBERS: F57E, F87E, F5JL, DUAL SPARK PLUG - ASSEMBLED
CH244C	244	4.0	1998 - 2000	98TM
CH244CA	244	4.0	1998 - 2000	98TM - ASSEMBLED
CH300A	300	4.9	1987 - 1996	E7TE - WITH SMOG - WITH EXHAUST SEATS
CH300AA	300	4.9	1987 - 1996	E7TE - WITH SMOG - WITH EXHAUST SEATS - ASSEMBLED
CH300B	300	4.9	1987 - 1996	E7TE - NO SEAT INSERTS WITH SEAT POCKETS
CH415ND	415	6.8	2008 - 2016	V10 3 VALVE DRIVERS SIDE-12MM SPARK PLUG -REPLACES CASTING NUMBERS: 5C3E
CH415NP	415	6.8	2008 - 2016	V10 3 VALVE PASSENGER SIDE-12MM SPARK PLUG- REPLACES CASTING NUMBERS: 5C3E

ISUZU

CH138N	138	2.3	1986 - 1995	4ZD1
CH156NE	2559CC	2.6	1988 - 1964	ZE1 - ROUND SHAPED COMBUSTION CHAMBER
CH156NEA	2559CC	2.6	1988 - 1996	4ZE1 - ROUND SHAPED COMBUSTION CHAMBER - ASSEMBLED
CH156NL	2559CC	2.6	1997 - 1997	4ZE1 - HEART SHAPED COMBUSTION CHAMBER
CH156NLA	2559CC	2.6	1997 - 1997	4ZE1 - HEART SHAPED COMBUSTION CHAMBER - ASSEMBLED

JEEP

CH150N	150	2.5	1987 - 2002	REPLACES CASTING NUMBERS: 2403, 117, 1/2' HEAD BOLT
CH150NA	150	2.5	1987 - 2002	REPLACES CASTING NUMBERS: 2403, 117, 1/2' HEAD BOLT. ASSEMBLED
CH226LN	225	3.7	2002 - 2004	LEFT HEAD / DRIVERS SIDE. REPLACES CASTING NUMBERS: 53020983, 53020983AB WITH EGR HOLE. BLOCK-OFF KIT INCLUDED
CH226RN	225	3.7	2002 - 2004	RIGHT HEAD / PASSENGER SIDE. REPLACES CASTING NUMBERS: 53020984, 53020984AB
CH227LN	225	3.7	2005 - 2012	LEFT HEAD / DRIVERS SIDE. REPLACES CASTING NUMBERS: 53020983AD, 53020983AC WITH EGR HOLE. BLOCK-OFF KIT INCLUDED
CH227RN	225	3.7	2005 - 2012	RIGHT HEAD / PASSENGER SIDE. REPLACES CASTING NUMBERS: 53020984AC
CH242N	242	4.0	1998 - 2006	331 CASTING
CH242NA	242	4.0	1998 - 2006	331 CASTING - ASSEMBLED
CH281LN	287	4.7	1999 - 2008	LEFT HEAD / 53020801AC, 53020803
CH281RN	287	4.7	1999 - 2008	RIGHT HEAD / 53020802, 53020804
CH318A	318	5.2	1992 - 2003	REPLACES CASTING NUMBERS: 53005714, 53006671, 53020466, 53020468. 172CC INTAKE RUNNER - 62CC COMBUSTION CHAMBER
CH318AA	318	5.2	1992 - 2003	REPLACES CASTING NUMBERS: 53005714, 53006671, 53020466, 53020468, 172CC INTAKE RUNNER - 62CC COMBUSTION CHAMBER.
CH318B	318	5.2	PERFORM.	WITH LA STYLE INTAKE BOLT PATTERN. REPLACES CASTING NUMBERS: 53005714, 53006671, 53020466, 53020468, 172CC INTAKE RUNNER - 62CC COMBUST. CHAMBER
CH318BA	318	5.2	PERFORM.	WITH LA STYLE INTAKE BOLT PATTERN. REPLACES CASTING NUMBERS: 53005714, 53006671, 53020466, 53020468, 172CC INTAKE RUNNER - 62CC COMBUST. CHAMBER ASSEMBLED
CH318A	360	5.9	1992 - 2003	REPLACES CASTING NUMBERS: 53005714, 53006671, 53020466, 53020468, 172CC INTAKE RUNNER - 62CC COMBUSTION CHAMBER
CH318AA	360	5.9	1992 - 2003	REPLACES CASTING NUMBERS: 53005714, 53006671, 53020466, 53020468, 172CC RUNNER - 62CC COMBUSTION CHAMBER. ASSEMBLED

MAZDA

CH122A	1998	2.0	1983 - 1987	FE - SOHC
CH122AA	1998	2.0	1983 - 1987	FE - ASSEMBLED
CH122A	2184	2.2	1987 - 1993	F2 - SOHC
CH122AA	2184	2.2	1987 - 1993	F2 - ASSEMBLED
CH140A	152	2.5	1998 - 2001	REPLACES CASTING NUMBERS: F57E, F87E, F5JL, DUAL SPARK PLUG
CH140AA	140	2.3	1995 - 1997	REPLACES CASTING NUMBERS: F57E, F87E, F5JL, DUAL SPARK PLUG - ASSEMBLED
CH157N	2606CC	2.6	1989 - 1994	G6
CH157NA	2606CC	2.6	1989 - 1994	G6 - ASSEMBLED

CYLINDER HEADS

PART #	CID	LITER	YEARS	NOTES
--------	-----	-------	-------	-------

NISSAN

CH1211	1982	2.0	INDUSTRIAL	H20-II / H25
CH1211A	1982	2.0	INDUSTRIAL	H20-II / H25 - ASSEMBLED
CH152N	126	2.1	INDUSTRIAL	K21 / K25
CH152NA	126	2.1	INDUSTRIAL	K21 / K25 - ASSEMBLED
CH146N	146	2.4	1983 - 1989	Z24

TOYOTA

CH132N	1998	2.0	1997 - 2001	3SFE - 16 VALVE DOHC WITHOUT DISTRIBUTOR HOLE WITH CAM SENSOR
CH136N	1998	2.0	1984 - 1985	3YEC - 8 VALVE OHV
CH136NA	1998	2.0	1984 - 1985	3YEC - 8 VALVE OHV - ASSEMBLED
CH132N	2164	2.2	1997 - 2001	5SFE - 16 VALVE DOHC WITHOUT DISTRIBUTOR HOLE WITH CAM SENSOR
CH136N	2237	2.2	1986 - 1989	4YEC
CH136NA	2237	2.2	1986 - 1989	4YEC - ASSEMBLED
CH144N	144	2.4	1985 - 1995	22R, 22REC
CH144NA	144	2.4	1985 - 1995	22R, 22REC - ASSEMBLED - NO CAM
CH164B	2438	2.4	1997 - 2000	2RZFE - DOHC 16 VALVES - 8 PORT- INCLUDES DISTRIB. / CAM SENSOR BLOCK-OFFS
CH164B	2694	2.7	1994 - 2000	3RZFE - DOHC 16 VALVES - 8 PORT- INCLUDES DISTRIB. / CAM SENSOR BLOCK-OFFS
CH164A	2694	2.7	2005 - 2013	2TRFE - DOHC
CH164AA	2694	2.7	2005 - 2013	2TRFE - DOHC - ASSEMBLED - NO CAM

INDUSTRIAL/FORKLIFT

Manufacturer	Description
FORD CH300A	E7TE - WITH SMOG - WITH EXHAUST SEATS
FORD CH300AA	E7TE - WITH SMOG - WITH EXHAUST SEATS - ASSEMBLED
FORD CH300B	E7TE - NO SEAT INSERTS WITH SEAT POCKETS
MAZDA CH122AA	FE/F2 HEAD COMPLETE-NEW - ASSEMBLED
MAZDA CH122A	FE/F2 HEAD BARE-NEW
MAZDA CH122A	FE/F2 HEAD BARE-NEW
MAZDA CH122AA	FE/F2 HEAD COMPLETE-NEW - ASSEMBLED
MAZDA CH122A	FE/F2 HEAD BARE-NEW
MAZDA CH122AA	FE/F2 HEAD COMPLETE-NEW - ASSEMBLED
MAZDA CH122A	FE/F2 HEAD BARE-NEW
MAZDA CH122AA	FE/F2 HEAD COMPLETE-NEW - ASSEMBLED
MAZDA CH122A	FE/F2 HEAD BARE-NEW
NISSAN CH152NA	NISSAN K21 / K25 - ASSEMBLED
NISSAN CH152N	NISSAN K21 / K25
NISSAN CH1211A	NISSAN H20-II - ASSEMBLED
NISSAN CH1211	NISSAN H20-II
TOYOTA CH136NA	4Y HEAD COMPLETE-NEW - ASSEMBLED
TOYOTA CH136N	4Y HEAD BARE-NEW

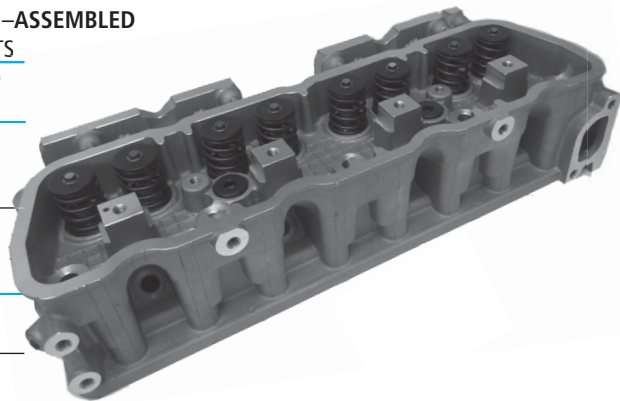

HEAD GASKET SETS

Manufacturer	Description
ISUZU GS4ZE1 2559cc	4ZE1 - 2.6 1988-1997
MAZDA GSFE-F2 1998	FE - 2.0 1983-1987
MAZDA GSFE-F2 2184	F2 - 2.2 1987-1993
MAZDA GSG6 2606cc	G6 - 2.6 1989-1994
MAZDA GSG64 2350cc	4G64 - 2.4 1993-1999
NISSAN GSK21N 126	K21 / K25 - 2.1 INDUSTRIAL
TOYOTA GS4Y 2237cc	4Y / 4YEC 2.2 1986-1989
TOYOTA GS22R 144	22R, 22REC - 2.4 1985-1995

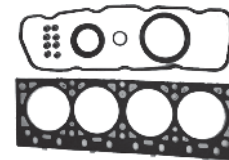

SCREW IN STUDS, SMALL BLOCK CHEVY

EACH CYL. HEAD REQUIRES THE USE OF A SCREW-IN ROCKER ARM STUD

ORDER# SIS350 (8 pcs. per set, enough for 1 cylinder head)

- STUDS MEASURE 7/16-14 X 3/8-24 X 2.375" OVERALL
- HEAT TREATED TO RC 33-39 AND ARE OXIDE



LS1 GEN III CYLINDER HEAD

Our LS1/2 Porters heads have been developed to provide porters and engine builders with a high quality LS casting as the platform for their port and chamber designs.

Part # EQ-CHLSBLNK

- Alloy: A356 virgin alloy
- Heat Treatment: T6
- Valve angle: 15°

BENEFITS

- CNC cut patterns for greater accuracy
- Hand rammed and hand poured for greater quality
- Chill plates for enhanced deck strength

WE TEST AND CHECK:

- Head is porosity free
- Dowel to inlet face measurement
- Dowel pin to engine block measurement
- HIP' d: No
- Angle: 15 degree
- Port entry: Inlet = 0.89" x 2.70" / Exhaust = 1.48" x 1.17"
- Valve Size: Inlet up to 2.08" / Exhaust up to 1.64"
- Valve Pierce Points: Inlet (0.83", 0.011") Exhaust (1.08", 0.011")
- Valve space: 1.91"
- Valve seats and guides: not included

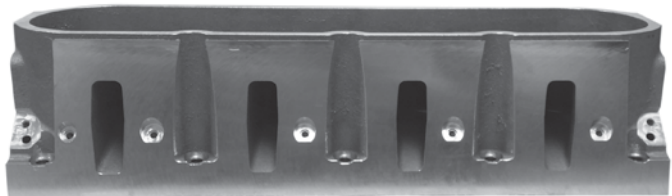
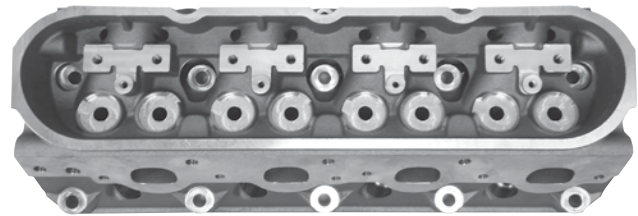
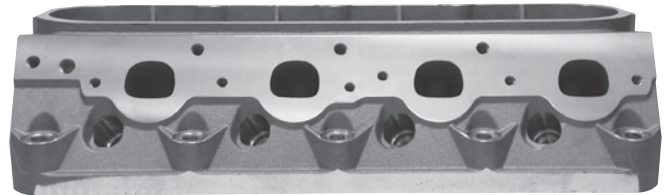
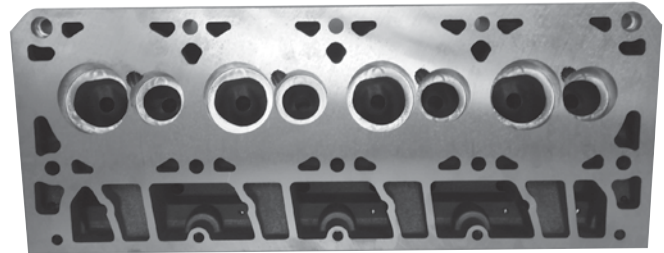

23 DEGREE CAST IRON PERFORMANCE HEAD

- AS CAST combustion chambers and ports
- DuraBond Exhaust Seats
- 3 angle valve job
- Thick deck faces for angle milling
- Phosphor bronze intake and exhaust guide
- Machined for guide plates and Screw In Studs
- Raised Intake Runner Ports for increased performance

PART #	INTAKE RUNNER VOLUME	COMBUST. CHAMBER VOLUME	SPARK PLUG HOLE	INTAKE VALVE	EXH. VALVE	GUIDE ID	GUIDE OD	INTAKE PORT WIDTH	INTAKE PORT HEIGHT	EXH. PORT WIDTH	EXH. PORT HEIGHT
CC200BA	200cc	64cc	Angle	2.02"	1.60"	.343"	.530/.531"	1.23"	2.12"	1.35"	1.35"

OEM INTERCHANGE

INTERCHANGE	PART #	OTHER	INTERCHANGE	PART #	OTHER	INTERCHANGE	PART #	OTHER	INTERCHANGE	PART #	OTHER
33002920	BA242N	CHRY	83502890	CB243N	CHRY	90TM	CH244A	FORD	D2RY6178B	DP171N	FORD
3896590	BA250N	GM	J3243155	CB243N	JEEP	93TM	CH244A	FORD	C2OZ6AA008A	DP302	FORD
352153	BA251N	GM	E80Z6287A	CE120I	FORD	98TM	CH244C	FORD	12338119	DP350	GM
458149	BA252N	GM	D0AZ6287A	CE1200	FORD	53020803	CH281LN	CHRY	B9AE6A008A	DP390	FORD
C5AZ6312A	BA289N	FORD	D5AZ6287A	CE121N	FORD	53020803	CH281LN	JEEP	C8SZ-6754-A	DT460	FORD
38577352	BA292N	GM	13515-37900	CE129N	TOYOTA	53020801AC	CH281LN	CHRY	E4TE9428CB	EN1097	FORD
E4DT6316A	BA302N	FORD	13517-37010	CE129N	TOYOTA	53020801AC	CH281LN	JEEP	E4TZ9426D	EN1097	FORD
458652	BA304N	GM	13571-35010	CE129N	TOYOTA	53020802	CH281RN	CHRY	F4TZ9430A	EN1698	FORD
10066046	BA305N	GM	11040-50K02	CH121I		53020802	CH281RN	JEEP	F4TZ9431A	EN1699	FORD
6272222	BA349N	GM	F2Y110100	CH122AA	HYSTER	53020804	CH281RN	CHRY	C5AZ6519B	FSP300N	FORD
8524946001	BA349N	MERC	HY-1360878	CH122AA	HYSTER	53020804	CH281RN	JEEP	C5AZ6519C	FSP300N	FORD
852946	BA349N	MERC	MD192297	CH124NA	CHRY	5302044	CH318A	CHRY	E5TZ6519B	FSP300N	FORD
863397	BA349N	MERC	12360424	CH134N	GM	53006671	CH318A	CHRY	E7TZ6519A	FSP300N	FORD
12551537	BA350N	GM	11101-71010	CH136NA	TOYOTA	...466	CH318A	CHRY	E7TZ6519A	FSP300N	FORD
75420	BA350N	MERC	11101-71030	CH136NA	TOYOTA	...624	CH350A	GM	E5TZ6519B	FSP300N	FORD
809892	BA350N	MERC	11101-73020	CH136NA	TOYOTA	...191	CH350B	GM	C5AZ6519C	FSP300N	FORD
809892T	BA350N	MERC	11101-76075-71	CH136NA	TOYOTA	...193	CH350B	GM	C5AZ6519B	FSP300N	FORD
E8TZ6316B	BA351N	FORD	F57E	CH140A	FORD	...062	CH350C	GM	351418S	FTP034	FORD
C8AZ6316B	BA390N	FORD	F5JL	CH140A	FORD	...906	CH350C	GM	F4ZZ6E086A	FTP034	FORD
D5TE6316	BA390N	FORD	F77Z6049AA	CH140A	FORD	938-883297	CH350C	MERC	10101-FY52K	GSK21N	NISSAN
3860008	BA396N	GM	87E	CH140A	FORD	10239906	CH350CA	GM	11044-FU460	GSK21N	NISSAN
6272225	BA400N	GM	F87Z6049AARM	CH140A	FORD ZZR-	12528913	CH350CA	GM	11044-FU400	GSK21N	NISSAN
D9TE6313FA	BA460N	FORD	010100ROA	CH140A	MAZDA	12558062	CH350CA	GM	11042-FY525	GSK21N	NISSAN
D9TZ6316C	BA460N	FORD	800124641	CH143AA	YALE	938-803860T	CH350CA	MERC	96059992	HB061A	
EAD6397A / B	BDV8F	FORD	11101-35060	CH144N	TOYOTA	3943627	CH359N	CHRY	96059992	HB061N	
FA1AZ6890B	BDV8F	FORD	117	CH150N	JEEP	3943627	CH359N	CUMM	96061591	HB097A	
14149R5	BL262U	MERC	2403	CH150N	JEEP	...567	CH395N	GM	96061591	HB097N	
841-9956	BL262U	MERC	11040-FY501	CH152NA	NISSAN	938-883492R1	CH454C	MERC	E4FZ6065A	HB098A	FORD
841-9690	BL262U	MERC	MD026520	CH154NA	CHRY	8M0046344	CH502A	MERC	10031210	HB122A	
10066061	BL262U	GM	MD151968	CH154NA	CHRY	11181-35050	CO144N	TOYOTA	10031213	HB122B	
10105867	BL262U	GM	53020983	CH226LN	CHRY	E43E6266A	CP140	FORD	10031214	HB122C	
10105867	BL262U	GM	53020983	CH226LN	JEEP	D4FZ6613A	CP140U	FORD	14086098	HB123A	
10172756	BL262U	GM	53020983AB	CH226LN	CHRY	E6AE6266BA	CP153	FORD	14086099	HB123B	
14099073	BL262U	GM	53020983AB	CH226LN	JEEP	4483620	CP202	CHRY	10101245	HB133A	
14093683	BL262U	GM	53020984	CH226RN	CHRY	C5AZ6269A	CP300N	FORD	2475886	HB133C	
10054727	BL350U	GM	53020984	CH226RN	JEEP	10088128	CP350N	GM	10234934	HB133C	
14093638	BL350U	GM	53020984AB	CH226RN	CHRY	10168501	CP350N	GM	6500754	HB134A	
841-9717	BL350U	MERC	53020984AB	CH226RN	JEEP	3173284	CW258N	CHRY	5601433	HB135A	
807695	BOPO87	MERC	0331	CH242N	JEEP	C1TE6278A	CW302N	FORD	E9DZ6065D	HB141B	FORD
12602540	BP085N	GM	53010334	CH242NA	JEEP	1618732	CW318N	CHRY			

BOLT ON!

EngineQuest®

HOLD ON!

800 426-8771

www.enginequest.com

ENGINEQUEST ENGINE PARTS AND CYLINDER HEADS

OEM INTERCHANGE

INTERCHANGE	PART #	OTHER	INTERCHANGE	PART #	OTHER	INTERCHANGE	PART #	OTHER	INTERCHANGE	PART #	OTHER
24573309	HB142A		14082317	HB350A	GM	12518043	OP350P	GM	3769966	TC318N	CHRYSLER
24573310	HB142B		14082315	HB350B	GM	47552A5	OP45A	MERC	10243967	TC350M	GM
6503562	HB143A		14082316	HB350C	GM	47552	OP45A	MERC	60660A1	TC350M	MERC
6503561	HB143B		10168527	HB350P	GM	14245	OPR262	MERC	14249A2	TC350M	MERC
90105-12092	HB144A	TOYOTA	10168526	HB350P	GM	14246	OPR262	MERC	12558343	TC350P	GM
6503559	HB145A		10168525	HB350P	GM	14256	OPR350	MERC	12562818	TC350P	GM
6503560	HB145B		10-11966	HB350P	MERC	14257	OPR350	MERC	835005	TC350P	MERC
N 6035516	HB149		10-119671	HB350P	MERC	12553058	OPR350	GM	D40E6059	TC351A	FORD
6035514	HB149N		10-11968	HB350P	MERC	12553059	OPR350	GM	D7AE6059	TC351A	FORD
4007310	HB150A		C8SZ6065A	HB370A	FORD	14088501	OPR350	GM	D9TE6059	TC351A	FORD
40073011	HB150A		C8SZ6065B	HB370B	FORD	14088502	OPR350	GM	E7AZ6019A	TC351A	FORD
4007308	HB150B		14077193	HB381A	GM	90999-73072	PB22RH	TOYOTA	56103	TC351A	MERC
4007307	HB150C		F5AZ6065A	HB413N	FORD	E5T26A588A	RGFO	FORD	E0AE6059	TC351C	FORD
12337818	HB151A		3877668	HB454A	GM	12550002	RLG350	GM	E3AE6059	TC351C	FORD
10101702	HB151B		10141204	HB454A	GM	14093634	RLG350	GM	E6S26019B	TC351C	FORD
12338010	HB152A		3877669	HB454B	GM	17341T	RLG350	MERC	E7PA6019A	TC351C	FORD
12338012	HB152B		10141205	HB454B	GM	845754	RLG454	MERC	F1S26019A	TC351C	FORD
10044565	HB153A		10-49105	HB454N	MERC	850474	RLG454	MERC	E5AE6059FA	TC351E	FORD
12338006	HB153A		10-49106	HB454N	MERC	12551397	RLG454	GM	E8AE6059	TC351E	FORD
10044569	HB153B		10-8M0000463	HB454N	MERC	10046165	RLR262	GM	FOAZ6019A	TC351E	FORD
12337925	HB153B		10-8M0000482	HB454N	MERC	1015916	RLR263	GM	E7TE6059AA	TC351F	FORD
10044567	HB153C		14024244	HD173	GM	12551431	RLR264	GM	E7T26019A	TC351F	FORD
12338022	HB153C		14024244	HD350	GM	FOAZ6C515A	RLR302	FORD	F6726019AA	TC351F	FORD
MD020730	HB156A	CHRYSLER	3894327	HD454	GM	811662	RLR350	MERC	F6TE6059	TC351F	FORD
6504087	HB166A		17618T	IN350MB	MERC	14101116	RLR350	GM	F6T26019NA	TC351F	FORD
D1FZ6435A	HB171A	FORD	DT7E9521JA	IN887	FORD	14101116	RLR350N	GM	F1SE6059BC	TC351H	FORD
476543	HB173A	GM	E5TE9425FA	IN887	FORD	12561389	SBM350	GM	F6726019AA	TC351H	FORD
476573	HB173B	GM	14094802	IS173	GM	14091675	SBM350	GM	F87E6059AA	TC351H	FORD
D6T26065A	HB177A	FORD	90345-51006	JPP001	TOYOTA	16 54790	SBM350	QKSLVR	330850	TC454C	GM
D6T26065A	HB177N	FORD	90344-52003	JPP002	TOYOTA	4387580	SH153R	CHRYSLER	3885048	TC454C	GM
90910-02075	HB179A	TOYOTA	90344-53008	JPP003	TOYOTA	15122	SH350R	MERC	F6T26019MA	TC460C	FORD
MD065959	HB180A	CHRYSLER	90344-53011	JPP003	TOYOTA	9441003	SHD350	GM	E5T26019K	TC460N	FORD
E7DZ6965A	HB183A	FORD	12551757	OC350N	GM	14024244	SHD350	GM	E8TE6059	TC460N	FORD
F3DZ6065A	HB183A	FORD	36-18710002	OC350N	MERC	14080362	SHS350	GM	53006826AB	TC488B	CHRYSLER
E9DZ6065A	HB184N	FORD	38-18710	OC350N	MERC	16-54790	SMB350	MERC	53020971AF	TC488B	CHRYSLER
10100034	HB189A	GM	F4FZ6890A	OFA098	FORD	93423830	SP181N	GM	12523974	TCC305	GM
10227593	HB189A	GM	D4FZ6890A	OFA140	FORD	39332A1	SP181N	MERC	12531283	TCC305	GM
10100033	HB189B	GM	22538711	OFA142	GM	6031867	ST055	CHRYSLER	10243967	TCC349	GM
10227594	HB189B	GM	3241335	OFA150		14079567	ST173	GM	10243963	TCC350	GM
24505015	HB189C	GM	10004891	OFA151		1250948	TB046	GM	66215	TCC454	MERC
6504329	HB197N		466383	OFA173	GM	E9T26K282A	TB140N	FORD	3899675	TCD302	FORD
90110-10006	HB199N		E6DZ6890A	OFA183	FORD	E7Z26E008A	TB141N	FORD	F1T26023A	TM351A	FORD
90201-10344	HB199N		F0TZ6890A	OFA244	FORD	25532588	TB181	GM	354407	TM454C	GM
6101631	HB202A	CHRYSLER	3173226	OFA258	CHRYSLER	F3Z26019B	TC142I	FORD	D4FZ6L273A	TT140	FORD
90910-02077	HB206A		14081300	OFA262	GM	140100617	TC173A	GM	F4T26L273A	TT140	FORD
90910-02077	HB206N		11972	OFA262	MERC	14090537	TC173B	GM	XF2Z-6K254-BA	TT232	FORD
90109-10132	HB216N		12600225	OFA294A	GM	14024263	TC173C	GM	1F226K254AA	TT232A	FORD
E2DZ6065D	HB230B	FORD	12552357	OFA294B	GM	14024263	TC173C	GM	14244	VC262	MERC
25527831	HB231A	GM	D7AZ6890A	OFA302	FORD	14033526	TC173C	GM	14252	VC262	MERC
25525953	HB231B	GM	22-56876	OFA302	MERC	14048323	TC173C	GM	814504	VC262	MERC
25539869	HB231C	GM	3952301	OFA305	GM	24502348	TC181G	GM	10046193	VC262	GM
F4SZ6065A	HB232A	FORD	4104511A	OFA345	CHRYSLER	3923456	TC181N	GM	14091554	VC262	GM
F4SZ6065B	HB232B	FORD	3853870	OFA454	GM	59341A1	TC181N	MERC	C5AZ6582K	VC300N	FORD
6035514	HB244N	CHRYSLER	22-805632	OFA454	MERC	E6AE6059AE	TC183A	FORD	F1T26582C	VC300N	FORD
6035516	HB244N	CHRYSLER	C9AE6890A	OFA460	FORD	F2DE6059HA	TC183B	FORD	12555269	VC3502	GM
F7ZZ6065AA	HB256A	FORD	12573460	OGP294N	GM	F5DE6059AB	TC183C	FORD	58211	VC350M	MERC
F7ZZ6065BA	HB256B	FORD	14244	OP262M	MERC	308-296	TC232A	FORD	79961	VC350M	MERC
F1AZ6065A	HB280A	FORD	14082348	OP305L	GM	E4AE6059BB	TC232B	FORD	14095094	VC350M	GM
F3AZ6065A	HB280A	FORD	87758A1	OP350B	MERC	D9D6059BB	TC232C	FORD	52331A1	VC350M	MERC
F5AZ6065A	HB280A	FORD	47549	OP350B	MERC	E7DE6059FA	TC232C	FORD	79961T1	VC350M	MERC
F3ZZ6065B	HB302A	FORD	465221	OP350E	GM	F24E6059BA	TC232D	FORD	10211648	VC352L	GM
F3ZZ6065C	HB302B	FORD	12528916	OP350L	GM	F65E6059AE	TC232E	FORD	12555269	VC352L	GM
F3ZZ6065D	HB302C	FORD	10242245	OP350M	GM	53005768	TC242R	CHRYSLER	809995	VC352L	MERC
F3ZZ6065B	HB302N	FORD	12529174	OP350M	GM	12554555	TC262P	GM	17671	VC454	MERC
F3ZZ6065C	HB302N	FORD	12559020	OP350M	GM	12554557	TC262P	GM	14089209	WK173	GM
F3ZZ6065D	HB302N	FORD	13840A1	OP350M	MERC	809893	TC262P	MERC	11060-50K00	WPH20	NISSAN
6034691	HB318A	CHRYSLER	805930A1	OP350M	MERC	863396	TC262P	MERC	11060-50K00	WPH20	TCM
6034960	HB318B	CHRYSLER	12518043	OP350N	GM	E5TE6019H	TC300N	FORD	11060-50K00	WPH20	KOMAT
12558840	HB349N	GM	12559020	OP350N	GM	53006705	TC318C	CHRYSLER	982021	WTC350N	MERC
12560744	HB349N	GM	808588	OP350N	MERC	53020196	TC318D	CHRYSLER	98602	WTC350N	MERC
12560745	HB349N	GM	809910	OP350N	MERC	2951698	TC318N	CHRYSLER	98602 1	WTC350N	MERC

EQ CYLINDER HEAD FLOW NUMBERS

EQ STRICTLY BY THE NUMBERS, HOW OUR HEADS STACK UP.

Need to know how our numbers compare against the competition? We provide you with the following extensive list of cylinder head flow numbers to help you decide.

CH318A/CH318B

INTAKE		EXHAUST	
LIFT	CFM	LIFT	CFM
.100	68.2	.100	57.2
.200	124.1	.200	114.1
.300	179.6	.300	155.3
.400	213.8	.400	180
.500	227.	.500	187.3
.600	233.1	.600	188.7
.700		.700	

CH350I

INTAKE		EXHAUST	
LIFT	CFM	LIFT	CFM
.100	71.2	.100	59.4
.200	134.6	.200	105.2
.300	189.4	.300	139.8
.400	216.9	.400	144.1
.500	225.8	.500	144.5
.600	213.4	.600	142.3
.700	212.2	.700	143.1

CH350C

INTAKE		EXHAUST	
LIFT	CFM	LIFT	CFM
.100	71.2	.100	59.4
.200	134.6	.200	105.2
.300	189.4	.300	139.8
.400	216.9	.400	144.1
.500	225.8	.500	144.5
.600	213.4	.600	142.3
.700	212.2	.700	143.1

CH350G

INTAKE		EXHAUST	
LIFT	CFM	LIFT	CFM
.100	71.2	.100	59.4
.200	134.6	.200	105.2
.300	189.4	.300	139.8
.400	216.9	.400	144.1
.500	225.8	.500	144.5
.600	213.4	.600	142.3
.700	212.2	.700	143.1

CH350H

INTAKE		EXHAUST	
LIFT	CFM	LIFT	CFM
.100	71.2	.100	59.4
.200	134.6	.200	105.2
.300	189.4	.300	139.8
.400	216.9	.400	144.1
.500	225.8	.500	144.5
.600	213.4	.600	142.3
.700	212.2	.700	143.1

CH454A

INTAKE		EXHAUST	
LIFT	CFM	LIFT	CFM
.100	75.9	.100	66.
.200	144.2	.200	126.6
.300	214.5	.300	168.9
.400	273.9	.400	204.6
.500	326.4	.500	231
.600	355.6	.600	252.9
.700	362.8	.700	271.2

CH454B

INTAKE		EXHAUST	
LIFT	CFM	LIFT	CFM
.100	77.7	.100	72.9
.200	141.5	.200	128.3
.300	209.4	.300	169.9
.400	271.9	.400	206.2
.500	325.6	.500	228.1
.600	259.4	.600	251.2
.700	371.2	.700	268.4
.800	375.7	.800	278.9

**DYNO RESULTS –
CAM .474" / .510" LIFT
Carb. 650 Holly
Run on ZZ4 short block**

CC200BA

RPM	TORQUE	POWER
2500	334.2	159.1
2600	358.3	177.3
2700	390.5	200.7
2800	396.2	211.2
2900	402.2	222.0
3000	100.3	228.6
3100	397.5	234.6
3200	395.5	241.0
3300	395.0	248.2
3400	397.2	257.1
3500	397.6	265.0
3600	398.8	273.4
3700	401.2	282.6
3800	403.8	292.1
3900	406.4	301.8
4000	409.2	311.7
4100	409.3	319.5
4200	407.4	325.8
4300	403.8	330.6
4400	399.5	334.7
4500	397.8	340.8

CH3502A

INTAKE		EXHAUST	
LIFT	CFM	LIFT	CFM
.100	74.2	.100	74.5
.200	142.6	.200	123.5
.300	220.4	.300	150.6
.400	270.2	.400	173.3
.500	302.4	.500	192.8
.600	314.7	.600	214.2
.700	320.4	.700	226.4
.800	278.9	.800	278.9

CC200BA

INTAKE		EXHAUST	
LIFT	CFM	LIFT	CFM
.100	74.8	.100	65.5
.200	137.2	.200	113.3
.300	185.7	.300	146.9
.400	225.	.400	170.2
.500	252.5	.500	181.7
.600	265.4	.600	187.8
.700	272.2	.700	189.5

The information in this catalog is from reliable sources and has been compiled with the utmost care, however, we cannot be responsible for errors. Listing in this catalog does not guarantee their availability.



EngineQuest®

SINCE 1987

Hub Central for Engine Builders

If you're an engine builder or rebuilder, your search for cylinder heads and specialty or hard-to-find engine parts begins and ends at EngineQuest® (EQ®).

We're 100% committed to getting you the right parts at the right time, at the right price. Looking for a cast iron or aluminum cylinder head casting?

We have thousands in stock. A timing cover? We offer the largest single line available.

From complete head bolt sets to exhaust manifolds, EQ puts the best selection of engine parts at your fingertips, so you can keep your project on track and get it done right the first time.



Cores

Supplies transmission and internal parts cores to the engine rebuilder and machine shop.

Recycling

This division recycles entire batteries, engines, transmissions, wheels (steel and aluminum) and radiators.

Auto Wrecking

Helps keep vehicles that are no longer roadworthy out of landfills and dumps.

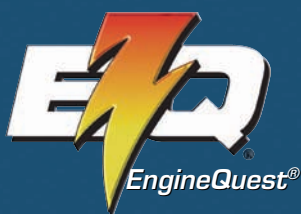

EngineQuest®

Specializes in unique, out-of-production or hard-to-find engine parts for all things automotive.



TransmissionQuest®

Offers automatic and standard transmission and transfer cases cores.

For 30 years, from
Front to Back,
we've been supplying the engine
rebuilder with the right part at
the right price, right now! How
can we help you...?

- CAM ECCENTRICS
- CAM PLATES
- CONVERSION ADAPTORS
- CYLINDER HEADS
- HARMONIC BALANCERS
- HEAD BOLTS
- MARINE COMPONENTS
- OIL FILTER ADAPTORS
- OIL PANS
- TIMING COVERS
- VALVE COVERS & MORE

ENGINEQUEST.COM

800/426-8771

